

PARTS

CS2 Brake Friction Module (Metric)

05-09-2023-1

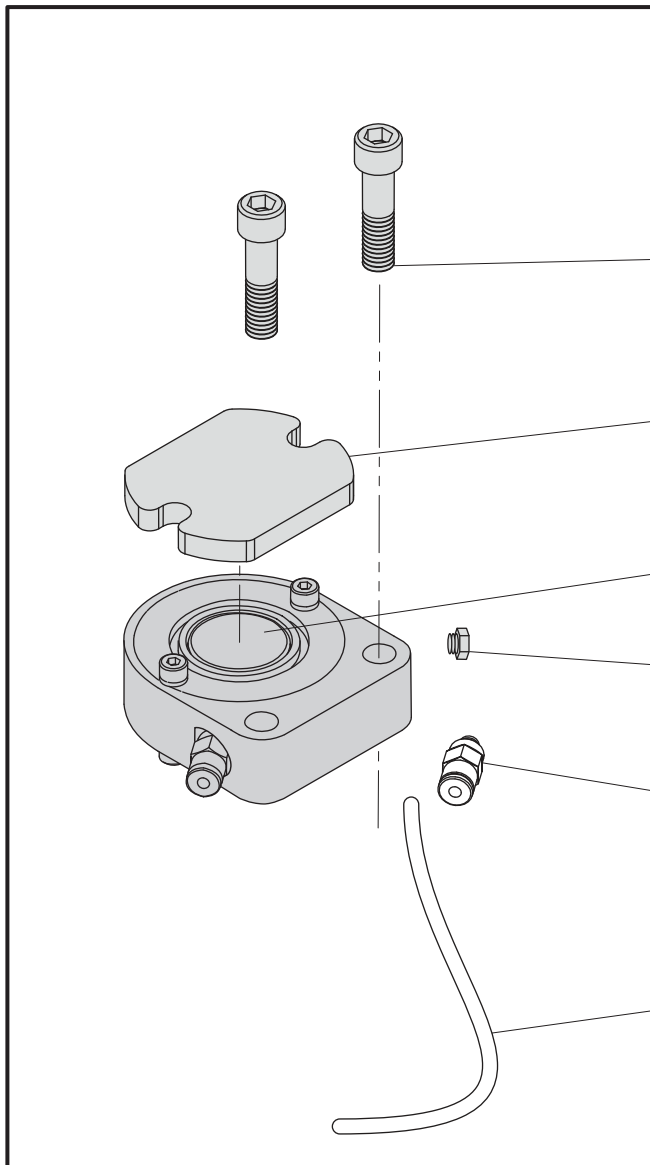

CS-2 FRICTION MODULE KIT

CS 100 / 130 10002059

MOUNTING BOLT (SHCS) x 2

M8-1.25 x 30 18000470

FRICTION PAD x1

Specify COF & Friction Mat'l.

MAGNET x1

10000265

PLUG x1

10-32 18000338

QUICK DISCONNECT x2

M5 x 4mm 18000674

TUBING x1

4mm TFE 20000324

QUICK DISCONNECT (supply line)

1/8" NPT x 4mm 18000882

(for upstream end of air SUPPLY line supplied with new brake)

ROTORS

Representative only - style varies by model and size (hub and fasteners not shown)

EU +45 75 57 27 11
DE +49 (0)511 760 691 41

Montalvo, 50 Hutcherson Drive, Gorham, Maine 04038 USA
info@montalvo.com www.montalvo.com
Prices and technical information subject to change without notice. © montalvo

EST. 1947 **montalvo**
Better Web Control®