

INSTALLATION AND OPERATION INSTRUCTIONS



D-3100ce-UW
Unwind Tension Controller
Version 3.0 Pub. date: 8/7/02 v2

Table of Contents

1 General Description	5
2 Technical Data	8
2.1 D-3100ce-UW Electrical	8
2.2 D-3100ce-UW Mechanical	9
2.3 RS-232 Communications Package (Optional)	10
2.4 Fieldbus Communications Package (Optional)	11
3 Installation and Setup	13
3.1 Mechanical Installation	13
3.2 Electrical Installation	16
3.3 Quick Setup Guide	17
3.4 Complete Wiring Diagram	26
3.5 Terminal Blocks	28
3.6 Basic Wiring Instructions	29
3.7 Digital Input: Standard Functions	32
3.8 Analog Signals: Standard Functions	47
3.9 Input and Output: Special Functions	48
3.10 Web Break	49
3.11 Range Expander of D-3100ce-UW	51
3.12 Diameter	56
3.13 Gain Control From Diameter	60
3.14 Operating the Controller Menu	62
3.15 Menu Tree Diagnostic and Setup	63
3.16 Menu Tree	64
3.17 Setup Menu	65
3.18 Hardware Adjustment and LEDs	66
4 Calibration	67
4.1 Dancer Calibration	67
4.2 Regulator Menu	68
4.3 Tuning	69
4.4 Customer Parameter Settings	70
5 Operation	71
6 Troubleshooting	73

1 General Description

The Montalvo D-3100ce-UW PID analog controller provides automatic control of the dancer position within the entire web control system. The progressive PID regulator automatically compensates for roll diameter. The D-3100ce-UW is used in a closed loop, of which the dancer roller and brake (or other tension-affecting device) are a part.

To properly set up and operate the D-3100ce-UW and to use all of its available features, it is important to have a general understanding of the controller and its place in the tensioning system (please refer to the diagram on the following page). A typical pneumatic system is shown; however, the same principles apply to any closed loop control system. The control outputs of 4 to 20 mA and 0 to 10 volts DC enable the D-3100ce-UW to interface with a variety of output devices to control web tensioning brakes, clutches, and motors.

Dancer Roller Function

A dancer with one or more wrap rollers can be applied. The controller receives a signal from a potentiometer that is placed at the pivot point of the dancer. The resulting change in voltage is amplified and calibrated at the regulator card.

Converter Function

The I/P converts the 4 to 20 mA regulator output to a proportional air pressure to control the brake. Other converters may be used, depending on the application.

Brake Function

One or more brakes may be controlled, converting the pneumatic output pressure from the I/P into torque. This torque changes the speed of the unwind roll to keep the dancer centered.

Auto Mode Function (Closed Loop)

The controller receives a signal from the position of the dancer roll potentiometer and automatically regulates the pressure to the brake until the dancer roll is in center position. The dancer roll indicates the difference in speed between the machine and the unwind roll. The movement of the dancer can be dampened either by means of a shock absorber or by the flow control valves of an air cylinder. Web tension is created only by the force of the dancer roll, which can be changed by weights, springs, or air cylinders.

Manual Mode Function (open loop)

No automatic regulation is done in manual mode. To set the brake pressure, and to maintain the dancer in the center position, the operator must make constant adjustments with the manual potentiometer.

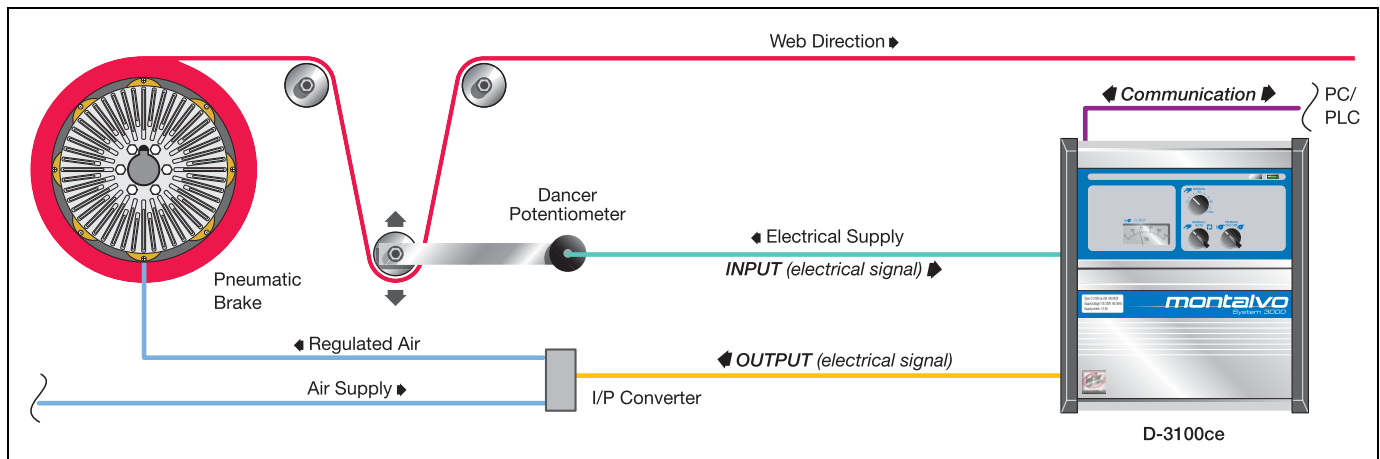

General Function and Standard Operation

Cabinet version

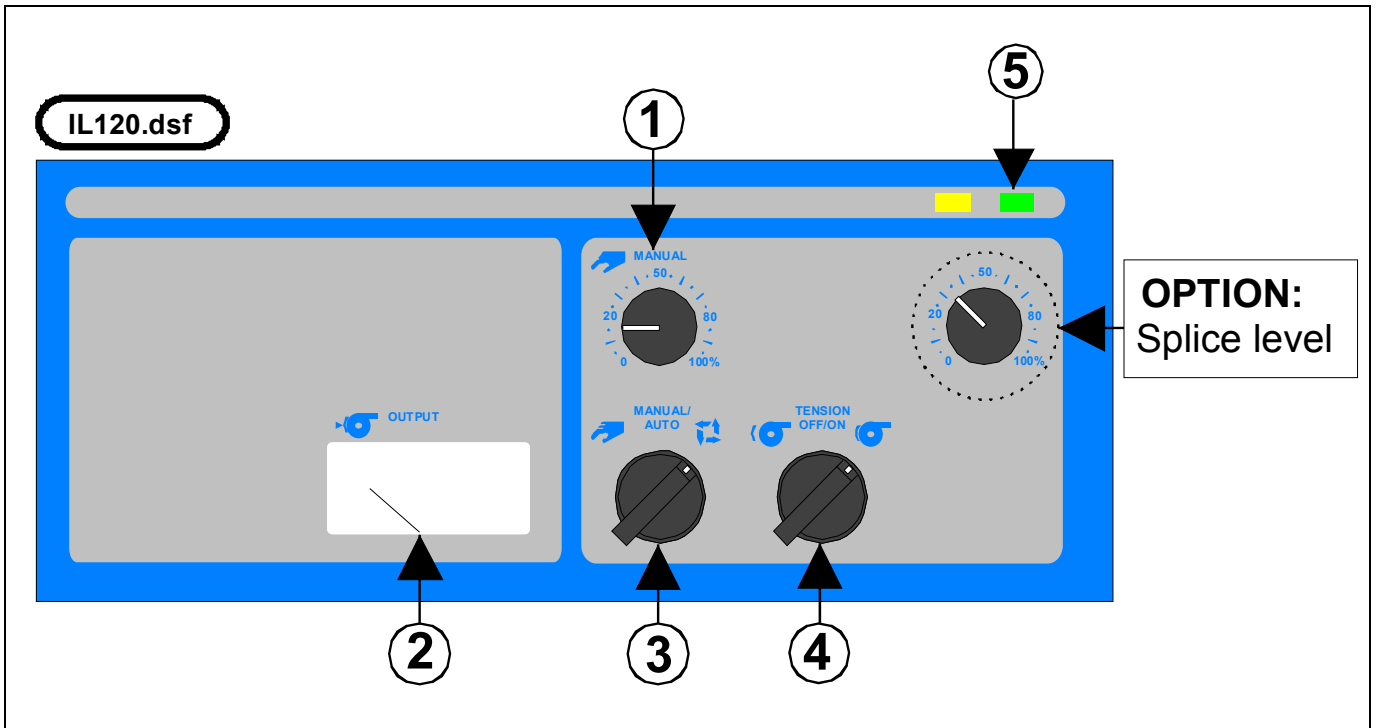

1. Manual setpoint potentiometer	Sets controller output at a constant level when controller is in manual mode. (The manual setpoint on 0 to 100% scale produces 0 to 100% output.)
2. Controller output	Displays controller/regulator output on a scale of 0 to 100%.
3. Manual / Auto switch	Changes the controller between manual and auto mode.
4. Tension off/on switch	Turns the dancer controller on and off. (When off, output is zero.)
5. Green power LED	Indicates that power is on.

2 Technical Data

2.1 D-3100ce-UW Electrical

AC Input	115 or 230 VAC $\pm 10\%$ 48 to 62 Hz
Fuse Size (fuse not installed by factory)	115 V - 160 mA T (slow-blowing type) $\varnothing 5 \times 20$ mm 230 V - 80 mA T (slow-blowing type) $\varnothing 5 \times 20$ mm (Both types are supplied)
Oversoltage Category	II (IEC 664) 2 kV in 1 minimum primary to secondary
Pollution Degree	2
Material Fire Classification	94 V0
Maximum Power Consumption	12 VA
Maximum Fuse Input	10A
Noise Immunity	EN 50082-2 industrial
Noise Emission	EN 50081-1
Dancer Potentiometer Supply	± 2.5 VDC $\pm 5\%$
Dancer Potentiometer Input	0 to ± 25 VDC
Zero Range (tare)	100% of dancer potentiometer
Calibration Range	Gain - 2 to 480
Temperature Range	0 to 50° C (32 to 122° F) operating -10 to 80° C (14 to 176° F) storage
Degree of Protection	IP 54/IP 10 for non-cabinet version
Regulator Outputs	0 to 10 VDC Maximum load - 5 mA 4 - 20 mA / 0-20 mA $R_L = 0$ to 1000 Ω
Meter Outputs	0 to 100 μ A $R_O = 100$ K Ω 0 to 10 VDC Maximum load - 5 mA
Analog Input Voltage	0 to 10 VDC $R_I = 1$ M Ω
Digital Input Voltage	15 to 30 VDC $R_I = 10$ K Ω
Digital Output Voltage	24 VDC $\pm 15\%$ I _{max} for a digital output - 100mA Total I _{max} for all 4 outputs 250mA (If internal power supply is used)
Standards	Designed to meet UL 508 and EN 60204

2.2 D-3100ce-UW Mechanical

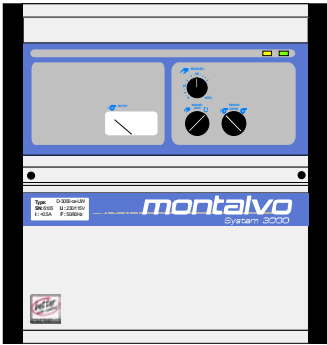
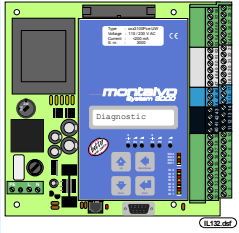
Dimensions (l x w x h) (Cabinet version)	230 x 260 x 163 mm (8.66" x 10.23" x 6.43")
Weight cabinet version)	3.6 kgs (7.92 lbs.)
Dimensions (l x w x h) (non-cabinet version)	160 x 160 x 55 mm (6.3" x 6.3" x 2.36")
Weight (non-cabinet version)	1 kg (2.2 lbs.)
Cabinet version	Non-cabinet version
	

2.3 RS-232 Communications Package (Optional)

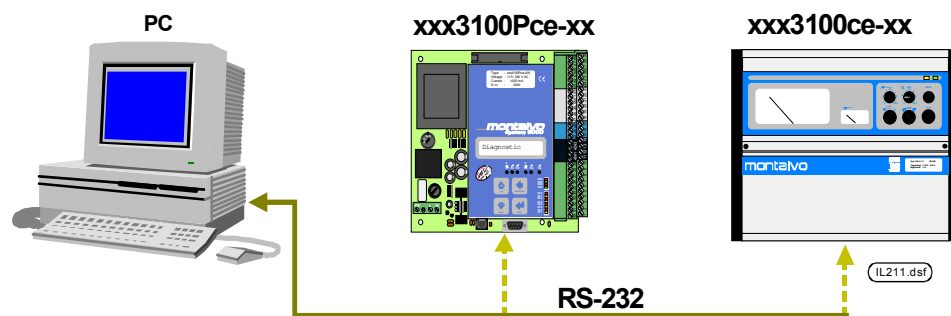

The System 3100ce has an optional **RS-232 Communications Package** for setting up and viewing the status of parameters from a PC or laptop. All items necessary for using RS-232 with the System 3100ce are included with this package.

The RS-232 communications package contains:

1. **CD-ROM** (software and PDF manual)
2. **RS-232 Cable** (RJ-11 to D-SUB 9 pin [4 m/12 ft.])
3. **User manual** (in hard copy).

The software package features two modes of operation:

1. **Parameter setup:** set up and back up all parameters with a PC or laptop.
2. **Remote control:** monitor the status of controller signals online.

Technical specifications for RS-232:

- **RS-232:** baud rate 4800-38400, 8 data bits, 1 stop bit and no parity (default 9600)
- **Remote setup:** all parameters on the controller are available for remote configuration.
- **Remote monitor(status):** for all digital and analog signals from the controller.

2.4 Fieldbus Communications Package (Optional)

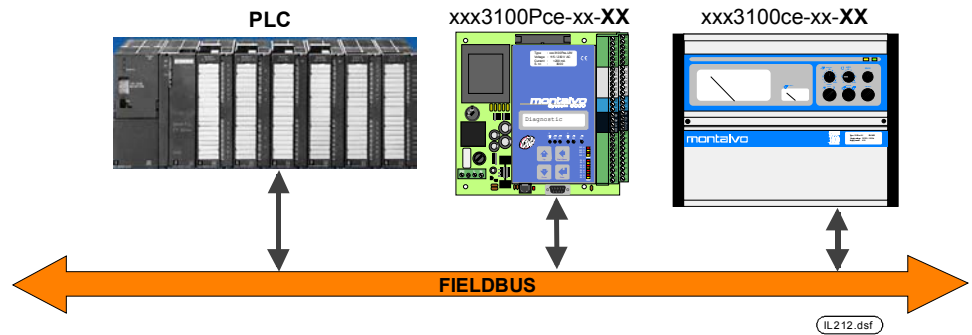

The 3100ce controllers can be delivered with a Fieldbus communication package option. Controllers with this package are named as follows:

xxx3100ce-xx-**PB Profibus**

Controllers with the Fieldbus option require the following:

- **CD-ROM** (GSD File and PDF Manual)
- **User Manual** (in hard copy)

Technical specifications for Fieldbus:

- **Profibus:** connection to the Profibus-DP with a D-SUB 9 pin. Maximum 12 mbaud.
- **Remote monitor (status):** all digital, analog, and internal signals from the controller.
- **Process control:** all digital and analog signals can be controlled from the master device (PLC).

3 Installation and Setup

3.1 Mechanical Installation

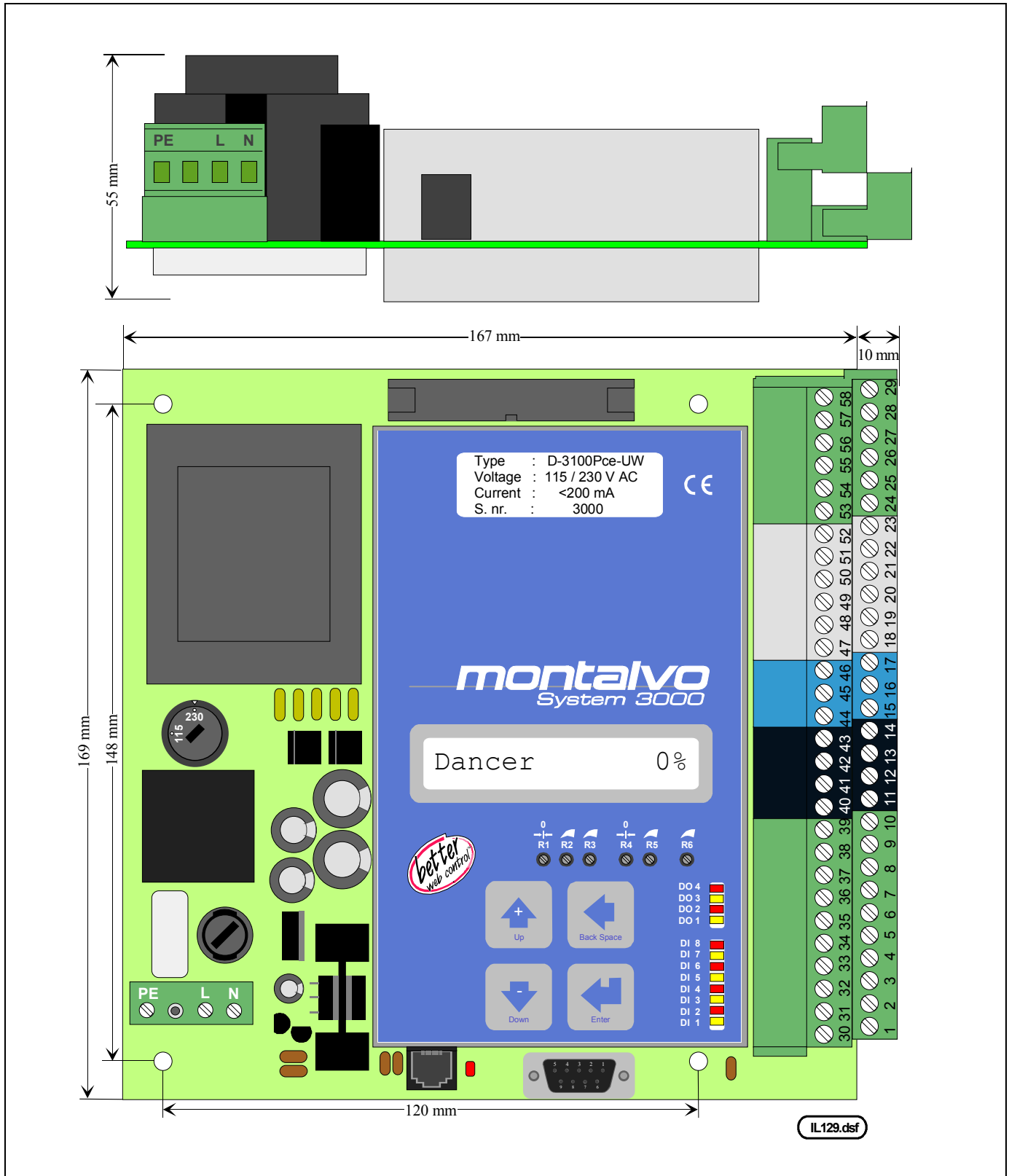

Avoid mounting the controller cabinet close to drive controllers or any other equipment that produces large amounts of EMI.

3.1.1 D-3100ce-UW Controller Cabinet

The D-3100ce-UW controller cabinet should be mounted in a dry place, away from any source of heat. The mounting surface should be free of any excessive vibration. If possible, the controller should be mounted at eye level and in a location accessible to the operator. Mount the I/P converter or P-3000 as close to the brake as possible.

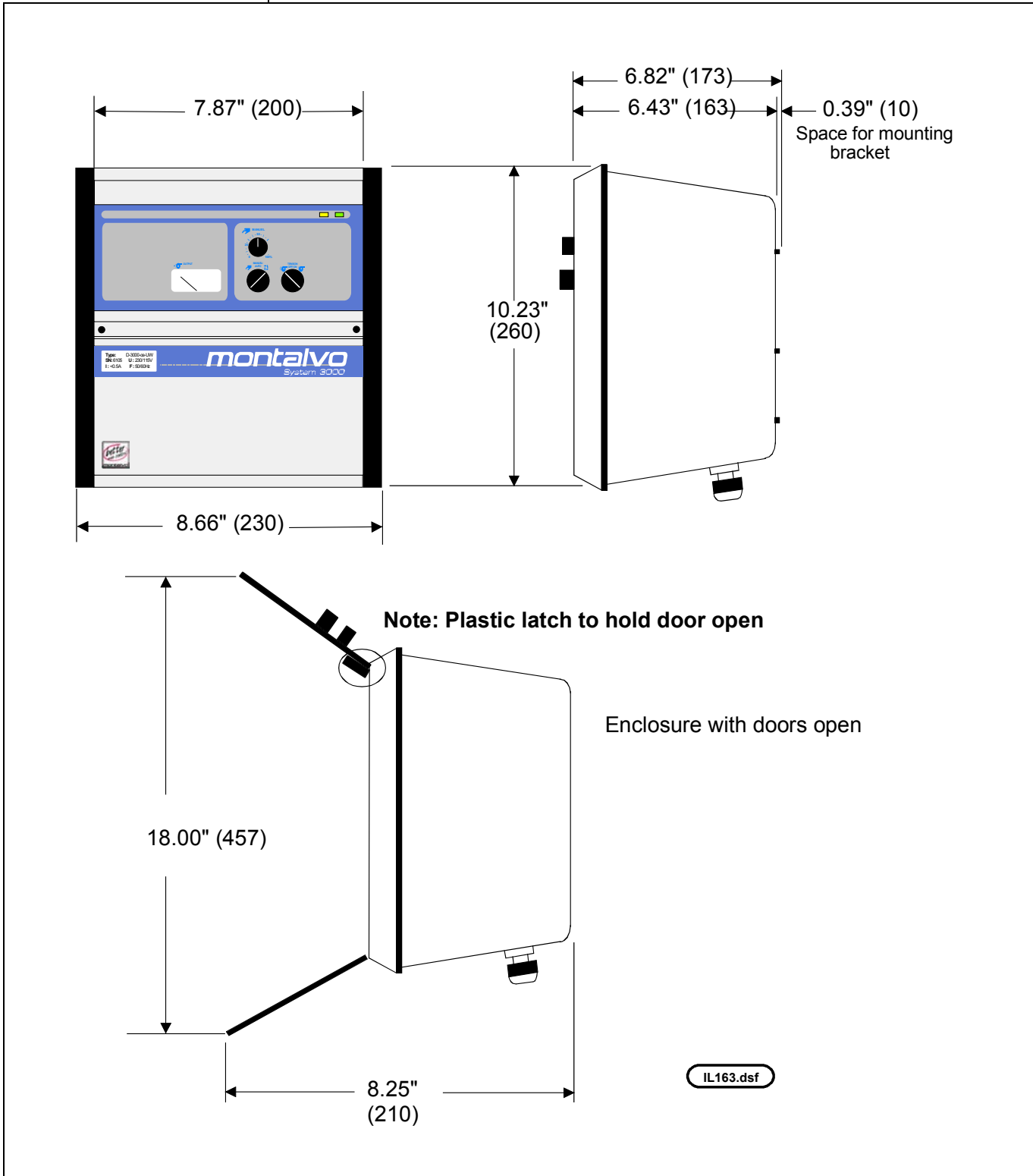

3.1.2 Cabinet Dimensions

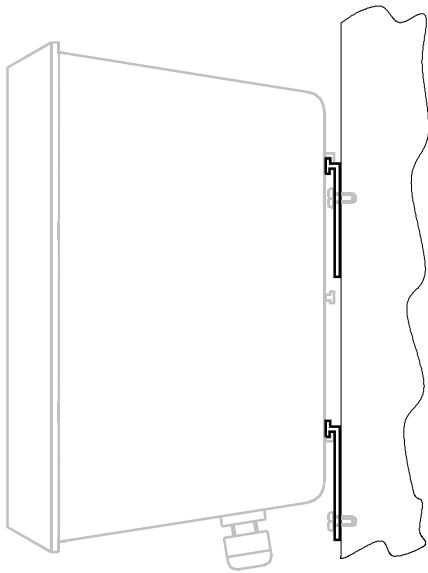

Fig. 1

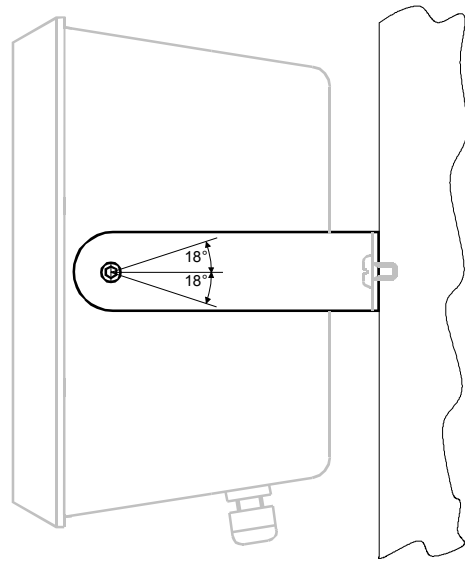

Fig. 2

Cutout dimensions: 220 x 250 mm

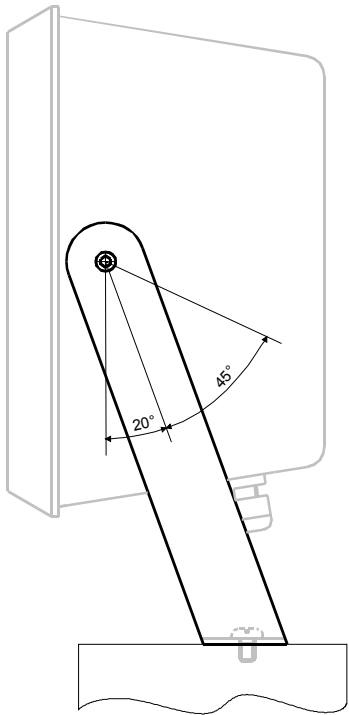

Fig. 3

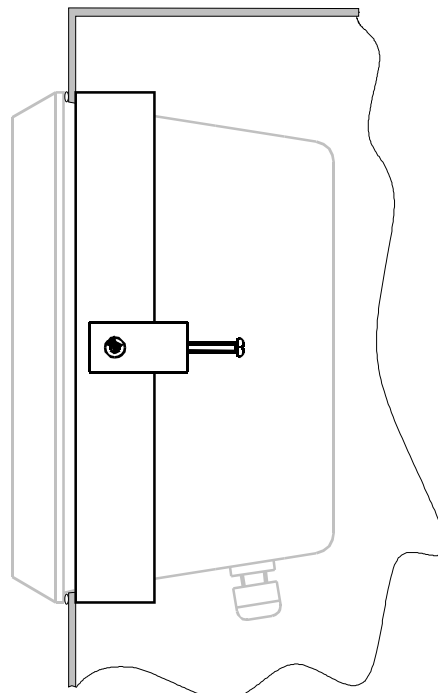

Fig. 4

IL036.dsf

3.2 Electrical Installation



Warning: *Electrical installation must be done by skilled personnel. Wiring must meet all applicable codes and standards.*

Refer to appropriate wiring and terminal descriptions for external connections.

Be sure that the voltage selector on the regulator PCB is in the correct position for the voltage supplied.

Select the PCB fuse size according to the input voltage selected. The maximum external fuse on the input is 10 A.

Note: *0VDC and PE are internally connected.*

Note: *Double-check accuracy of all wiring connections before applying power to the controller. Damage caused by improper wiring is not covered under warranty.*

EMC Requirements





Connect protective ground wire to terminal marked PE. Ground wires should be as short as possible. Connect PE, mounting plate, and cabinet to a common ground.

Use *only* shielded cable for all external connections. For analog signals, terminate shield at controller end; for digital signals, terminate shield at both ends. For cabinet versions, connect shield to the cabinet at the point where the cable enters, whether to a buss bar or to the connector housing. Keep the shield as short as possible (not to exceed 10 mm or 0.4 inches). For best results, clamp the uninsulated shield directly to the buss bar with the strain reliefs provided.

Keep signal cables away from supply cables or any wires that conduct high current. For best noise immunity, run signal cables close to the machine frame, mounting plates, or other grounded structures.

Safety Information

The following safety symbols appear in this manual.

	
Caution	Electrical Hazard
<i>Failure to follow installation and setup instructions in this manual may result in equipment damage or personal injury.</i>	<i>Failure to follow wiring instructions in this manual may result in equipment damage, personal injury, or death.</i>

The Quick Setup Guide is intended to help get the system up and running in a short period of time.

To maximize system performance, please read entire manual.

3.3 Quick Setup Guide

3.3.1 Introduction

The Quick Setup Guide describes a typical dancer system with the following components:

- 1 D-3100ce-UW
- 1 I/P converter (MPC 3, 4, or 5)
- 1 air filter (5 and 0.3 um)
- 1 dancer potentiometer
- 1 brake

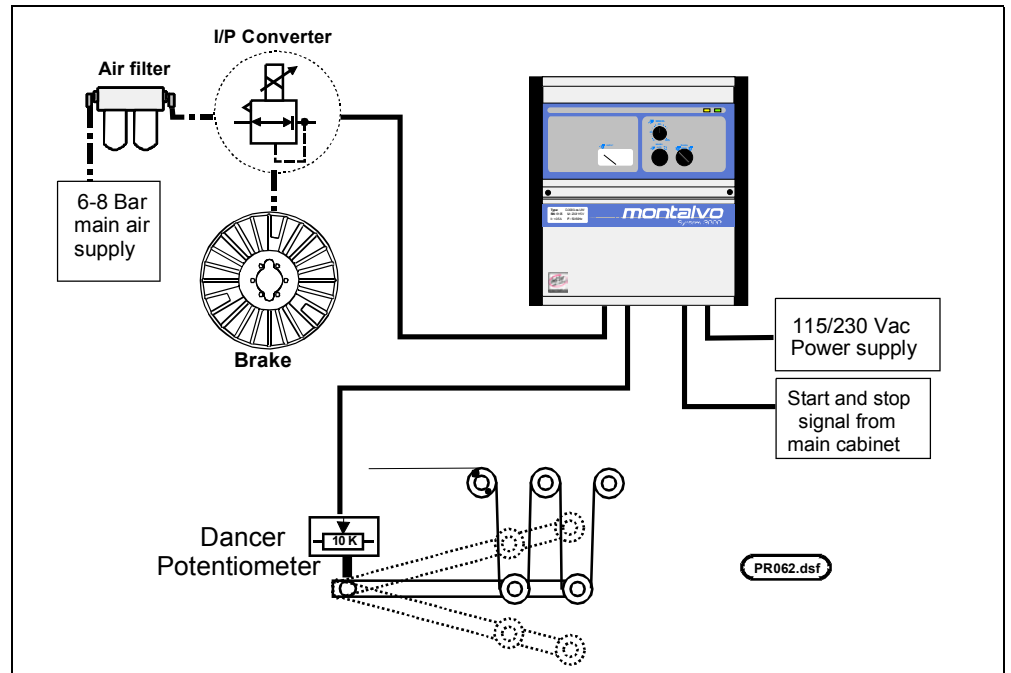

Note: *If the system includes other combinations of equipment, please refer to the appropriate sections in the manual.*

3.3.2 Mechanical and Pneumatic Installation

1. Mechanical Installation

Mount all components on machine.

Note: Place I/P converter close to brake so that tubing will be as short as possible.

2. Pneumatic Installation

Connect main air supply (1) to air filter (2), air filter to I/P-converter (3), and I/P converter to brake cylinders (4)(see diagram below).

Recommended: install an air pressure gauge (or manometer) in line with the brake if the gauge is not present on the I/P converter.

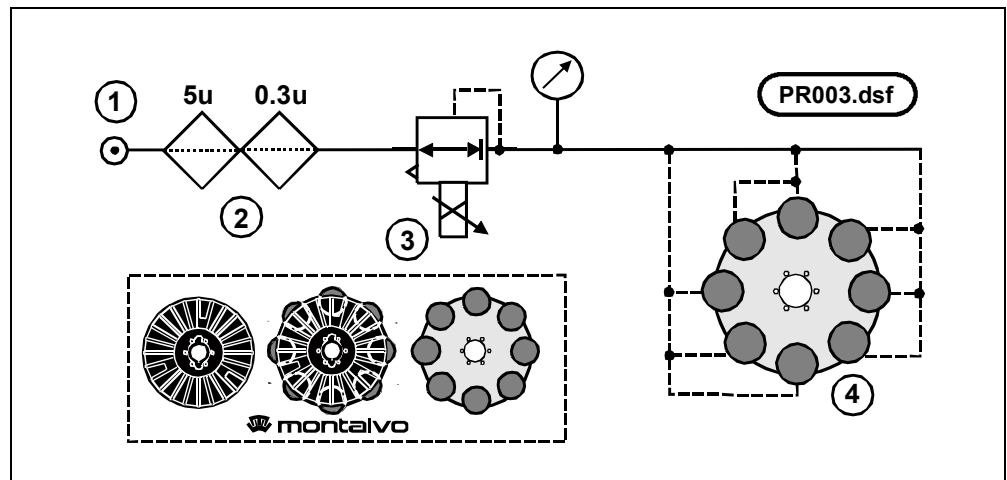

Pneumatic installation

3.3.3 Electrical Installation

1. I/P Converter

Connect cable from controller to I/P converter (see diagram below):

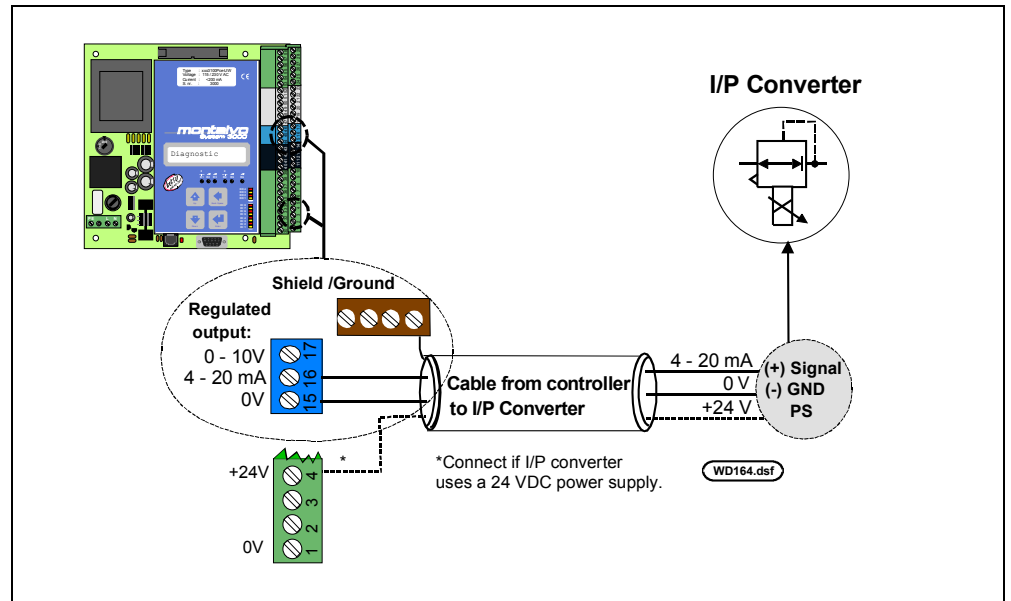

2. Dancer Potentiometer

Run cable from dancer potentiometer to controller, and connect cable from controller to dancer potentiometer (see diagram below):

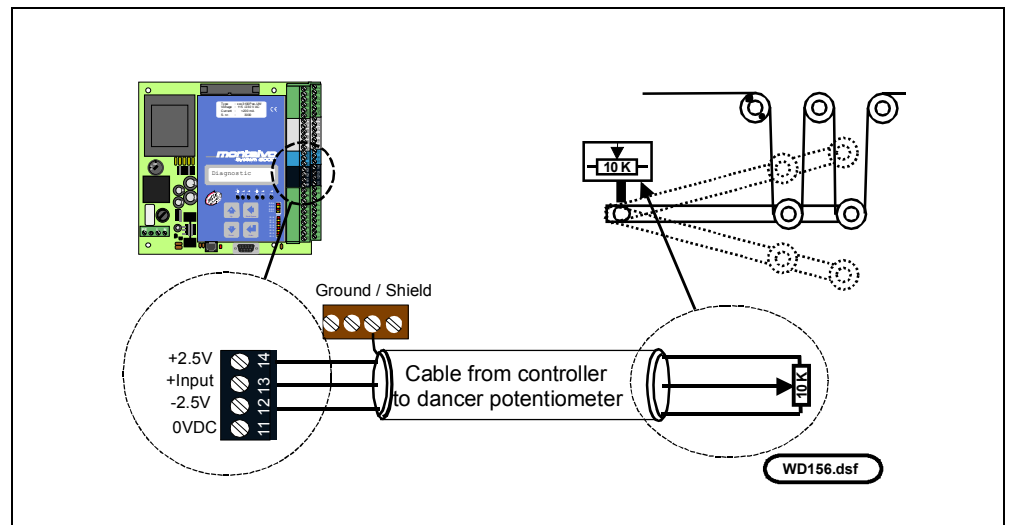

3. Connection of start/stop signal from machine main panel

Connect the cable between machine main panel and controller. Check that the signal comes from a relay with the following function:

- a) The relay must:
 - **energize** when machine starts running or moving

- **de-energize** when stop is pressed or when machine comes to complete stop (zero speed signal).

- From this relay use the *opening function (NC)*. The relay contact must be closed at stop and be open at start/operation (see Fig. 1):

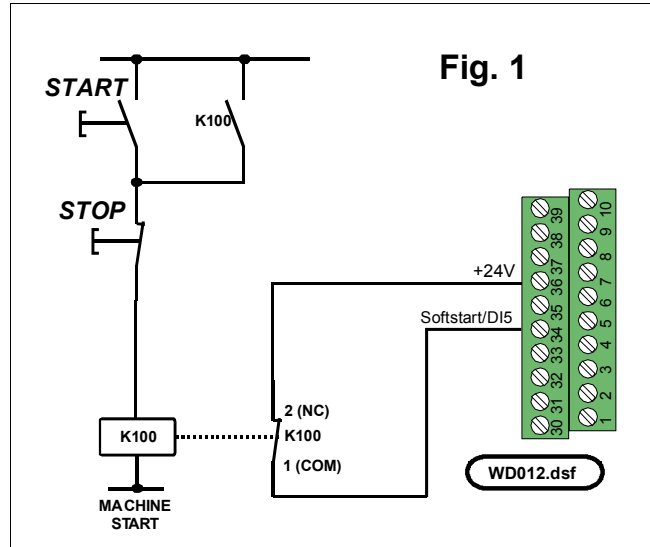

4. Connection of supply voltage to the controller:

Connect cable between machine main panel and controller. Choose a supply voltage (230/115 VAC) that is applied when the main switch to the machine main panel is turned on. Then:

- Turn off power in machine main panel.
- Connect cable in the machine main panel.
- Remove fuse from the fuse holder on the printed circuit board (PCB) if fuse is already installed.

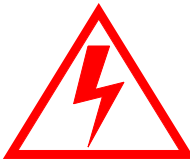

- d) Connect cable in the controller, as shown in the diagram below.

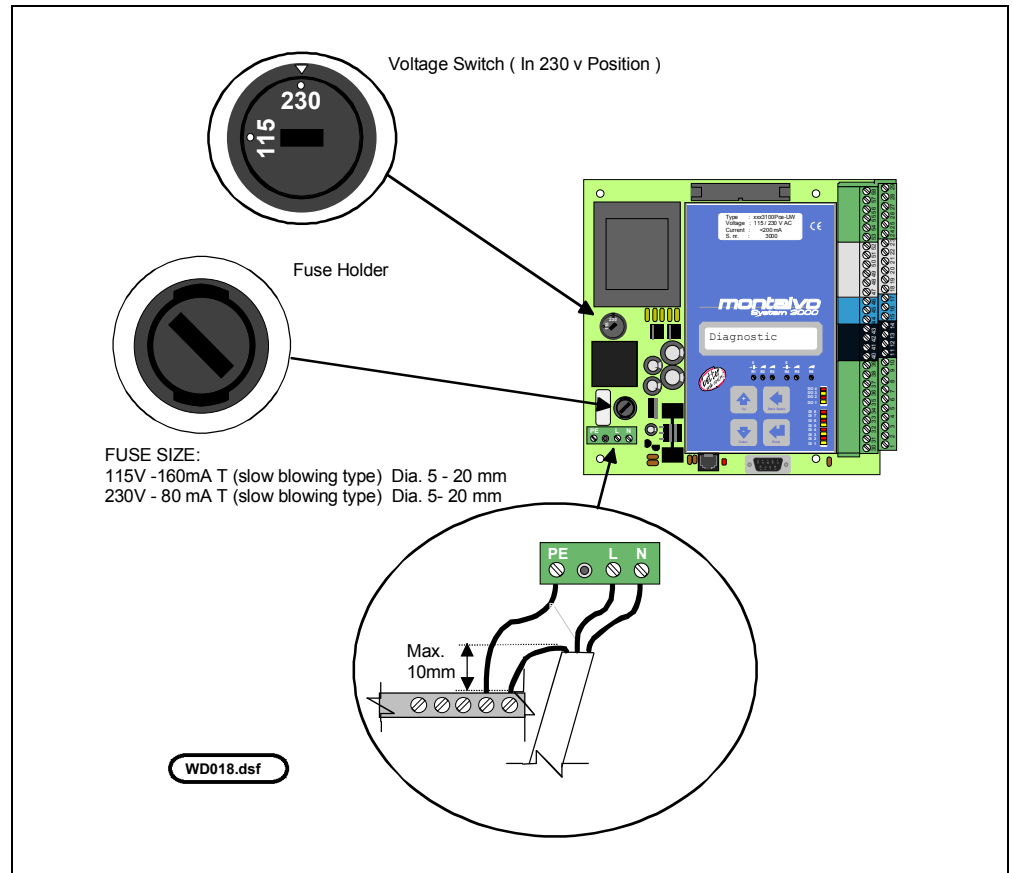

- e) Turn on power on machine main panel again. Using voltmeter, check connection of terminal points L, N and PE before inserting fuse.

Diagnostic
Version
Run Mode
Dancer
Setpoint
Output
I-Level
Manual
Splice
Summation
Diameter
Output2
Password
Setup Menu

3.3.4 Dancer Calibration

1. **Check** for correct installation of dancer potentiometer.
2. **Place** dancer roller in center position, loosen potentiometer coupling, and turn potentiometer shaft until it is approximately in center position (5kΩ between black and white wire). Tighten the coupling again.
3. **Apply** power to the controller and let it warm up for at least 10 minutes. Scroll to the dancer parameter in [DIAGNOSTIC].
4. **Place** the dancer roller in center position and adjust potentiometer R1 until the digital display shows [DANCER 0%] under the [DIAGNOSTIC] menu.

Note: R1 and R2 are 25-turn potentiometers, so many rotations may be required.

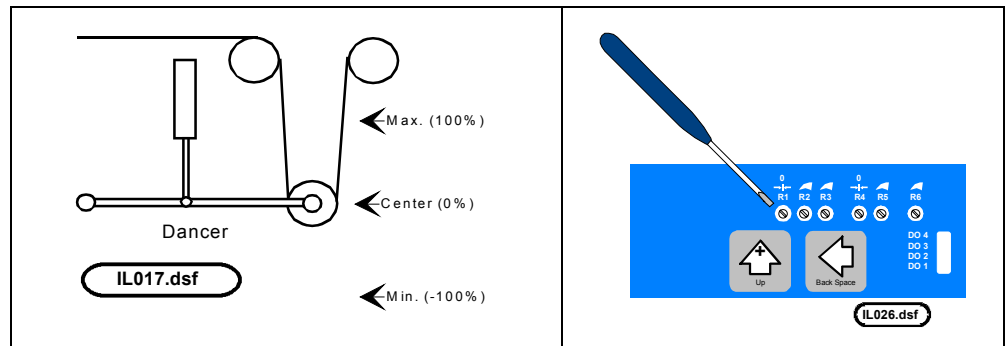

5. **Place** dancer roller in maximum position. If a negative value is displayed, switch the red and black wires coming from the potentiometer, and repeat step 4. Adjust potentiometer R2 until [DANCER 100%] appears. If the value is below 100%, turn R2 clockwise; if above, turn counterclockwise.

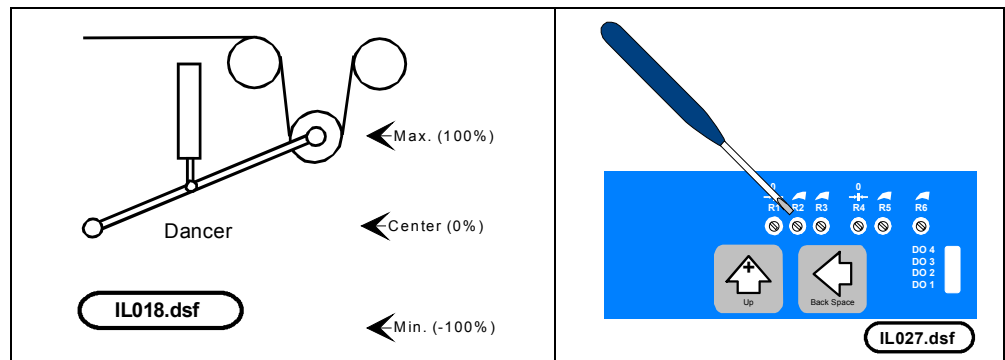

6. **Move** the dancer to the minimum position. The display should show -100%.
 - If the value is *under* -100%, **move** the center position toward *minimum* position.
 - If the value is *over* -100%, **move** the center position toward *maximum* position.
 - To **readjust** center position, **return** to step 4.

Note: For keypad use, see Section 3.14, p. 62.

Diagnostic
 Password
 Setup Menu
 Mode Menu
 Run Mode
 Amplifier
Regulator Menu
 Gain Min.
 Gain Max.
 Gain Mid.
 Sys. Gain
 P Level
 D Level
 Gain Src
Softs Menu
 Start Out
 Softs Lev.
 Softs Time
 Hold Level
 Anti Menu
 Anti.Src.
 Anti Max
 Anti Min
 Anti Slope
 Splice Menu
 Splice Src
 Splice Del
 Splice Lev
 Splice Tim
 WebBr Menu
 Webbr Lev.
 Webbr Time
 Range Exp.
 RE Source
 Ranges
 Start No.
 Dn Level
 Up Level
 Range Time
 Brake Menu
 Range Dia Menu
 Dia. Menu
 Diamet.Src
 P/Rev Roll
 mm/Pulse
 Min Diam.
 Max Diam.
 Fac. Diam
 DF AutoSet
 New Roll D
 Diameter
 Com Menu (optional)

3.3.5 Startup and Adjustment

	<p>Note: <i>The Quick Setup Guide is intended to get the system up and running in a short period of time. To maximize system performance, please read entire manual.</i></p> <p>Note: <i>For complete instructions on keypad use, see Section 3.14, p. 62.</i></p>
---	--

The system is now ready to start.

1. Scroll to the password menu. Press enter, then **up** arrow to change display to 5. Press **enter** again, then **down** arrow key. Password 5 allows access to setup menu.
2. Scroll to parameter [**Gain Min.**] under the setup menu.
3. Install a small roll in the unwind stand.
4. Run machine at low speed and adjust [**Gain Min.**] until dancer is steady but still responsive to variations.
5. Stop machine and scroll to parameter [**Gain Max.**] under the setup menu.
6. Install a large roll in the unwind stand.
7. Run machine at low speed and adjust [**Gain Max.**] until dancer is steady but still responsive to variations.
8. Scroll to [**Softs Menu**] and adjust softstart time [**Softs Time**] so that it fit machine's deceleration ramp.
 - If signal for start/stop (terminal 34) goes low before machine reaches zero speed, enter time between maximum and zero speed in parameter [**Softs Time**].
 - If signal to start/stop (terminal 34) goes low only when machine reaches zero speed, set time in parameter [**Softs Time**] at 0.2 seconds.

3.3.6 Basic Diagrams for Standard Application

Non-cabinet version

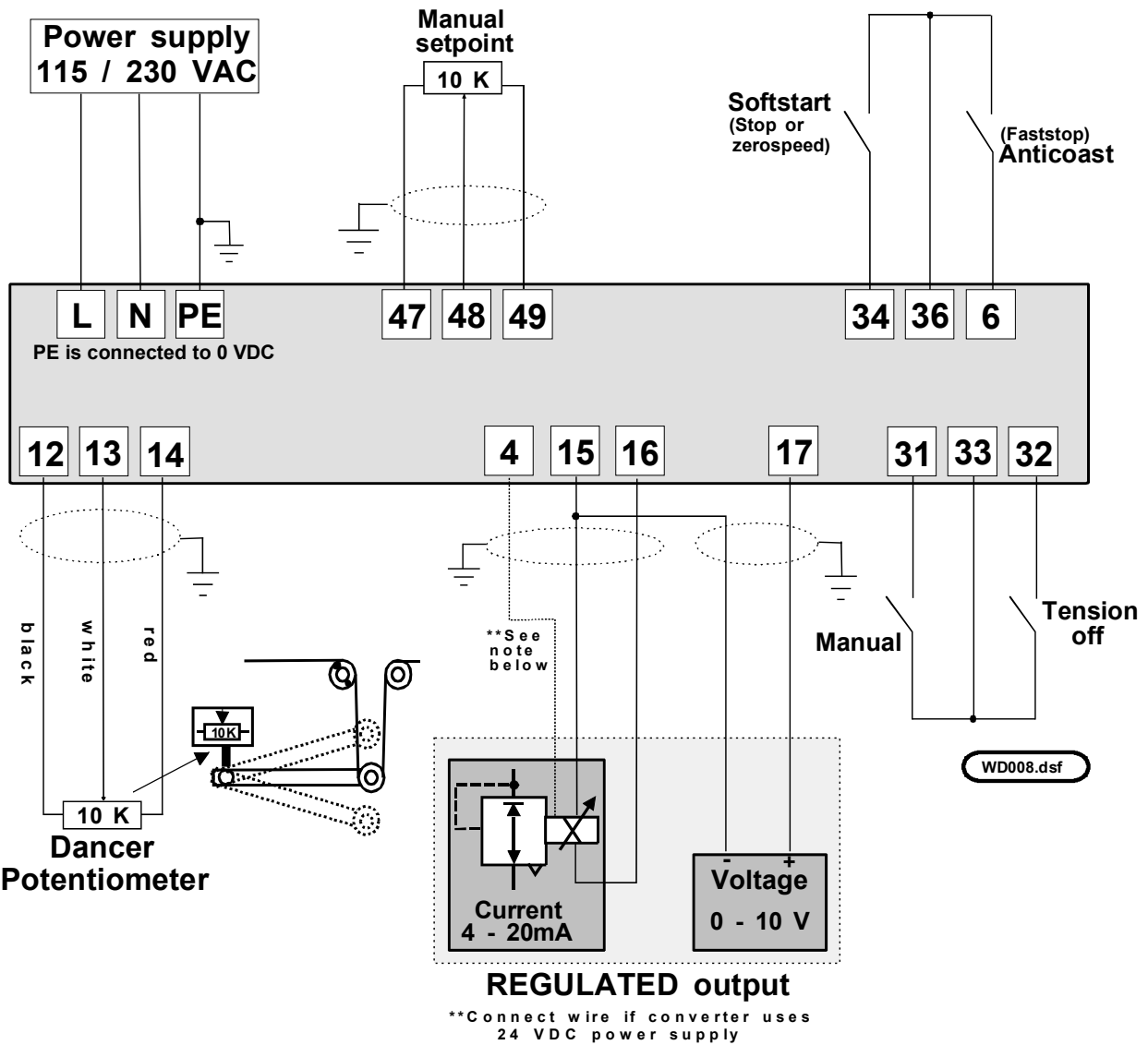
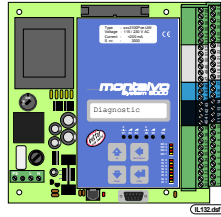

Cabinet version

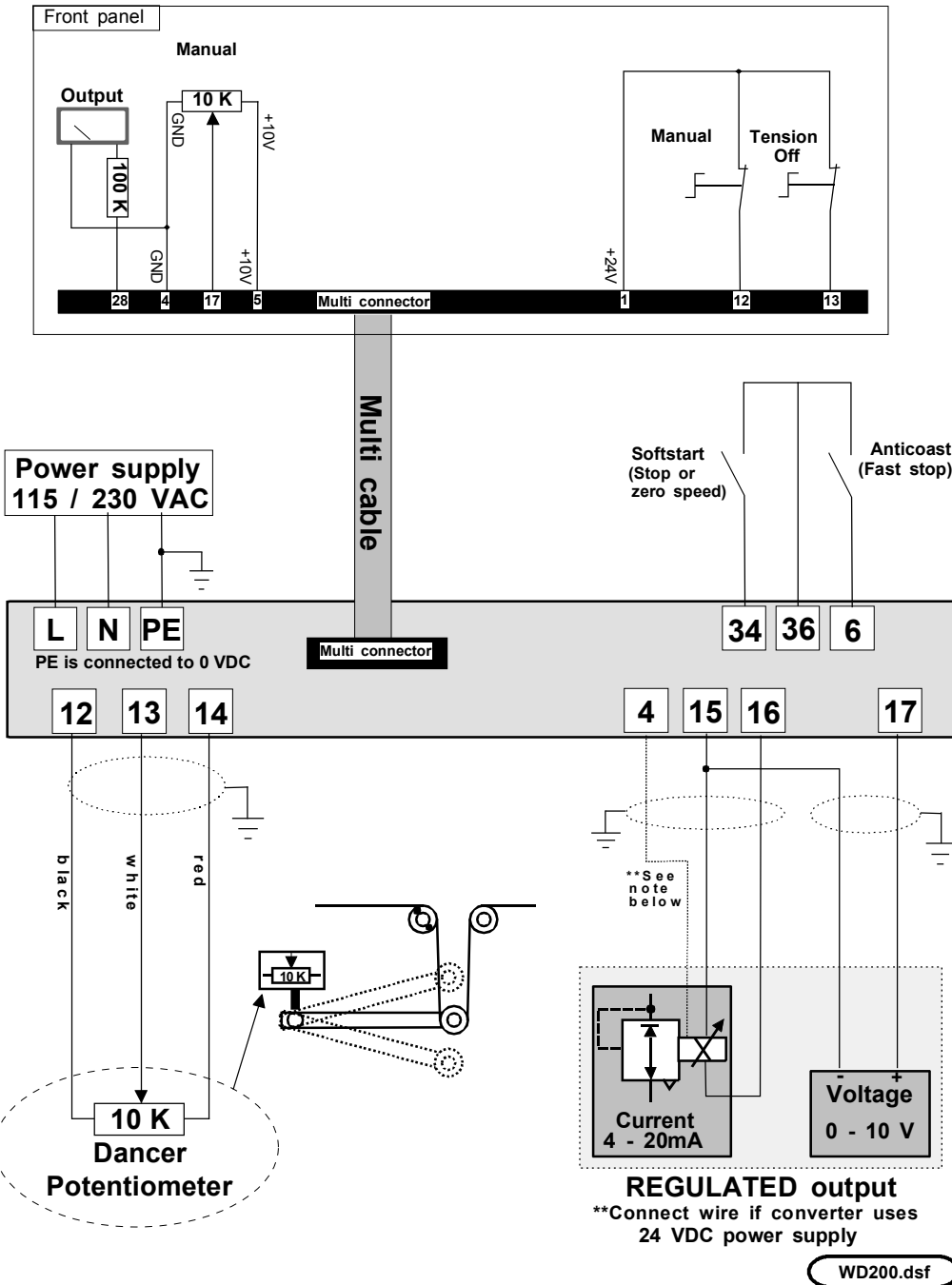
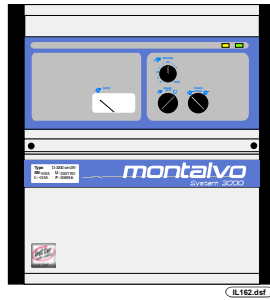

3.4 Complete Wiring Diagram

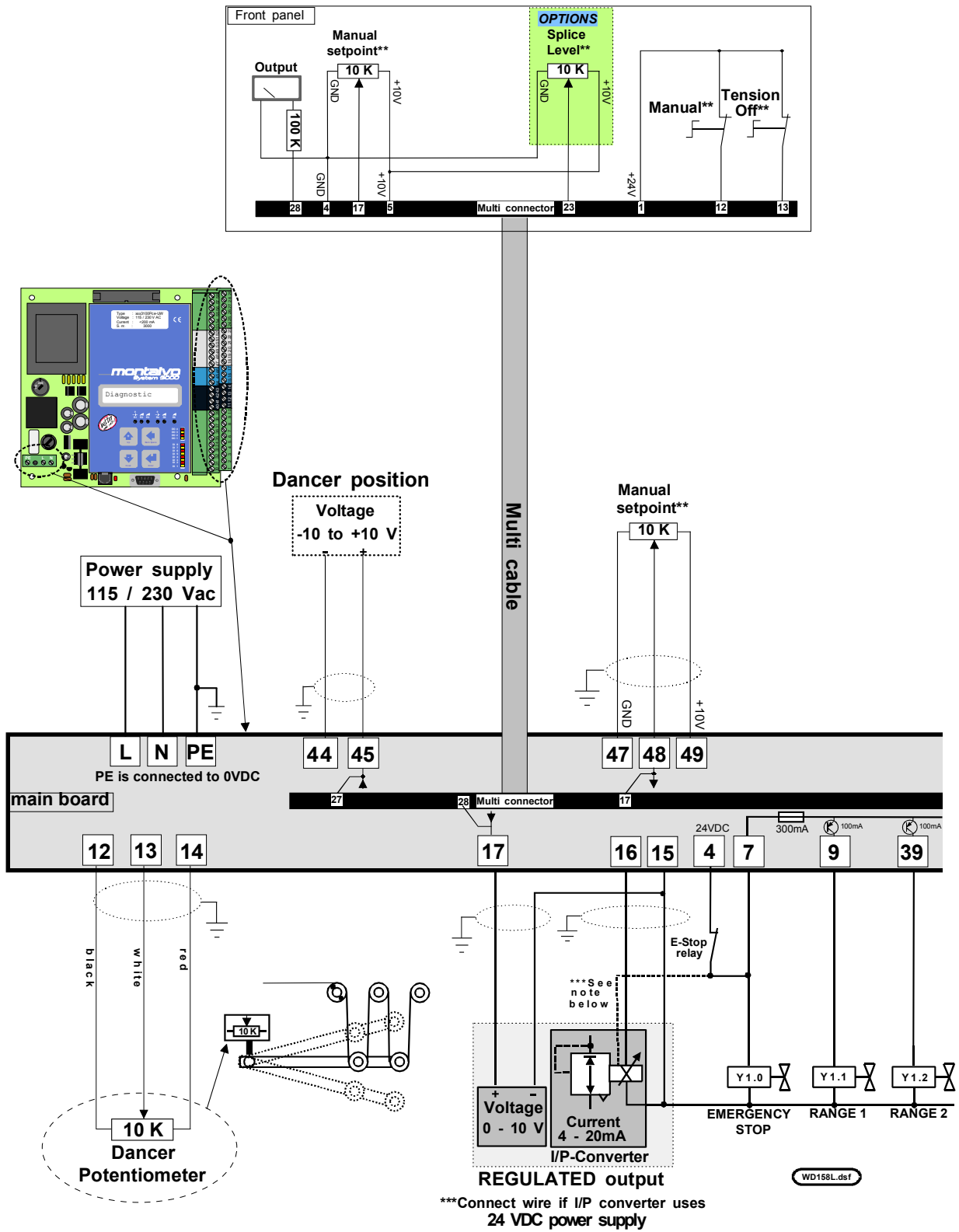

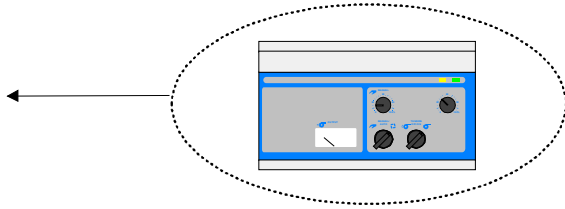

**** Analog signals (manual setpoint and splice level) and digital signals (manual and tension off) can only be used one place at the time. Signals used on the front panel cannot be used on the main board.**

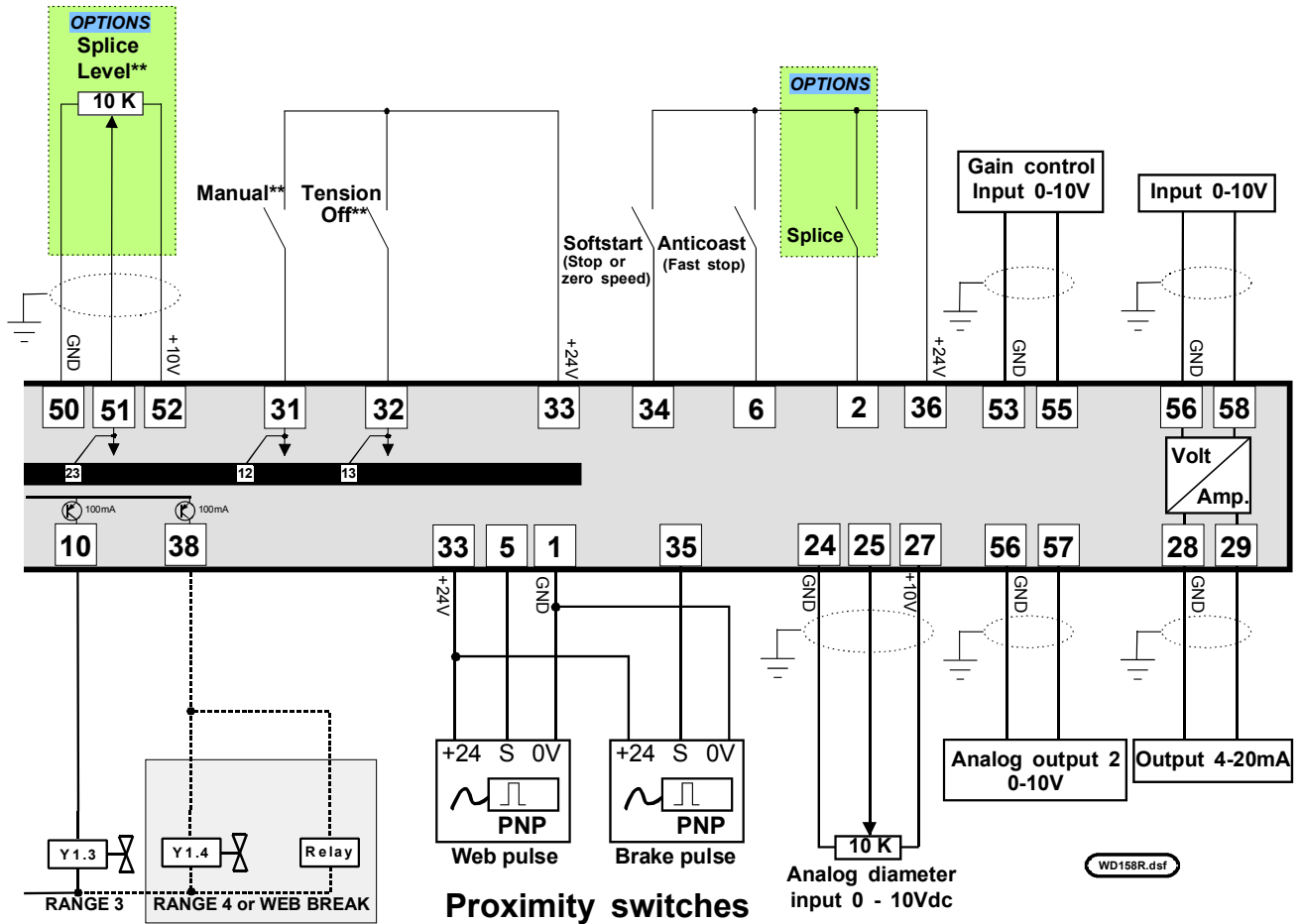

3.5 Terminal Blocks

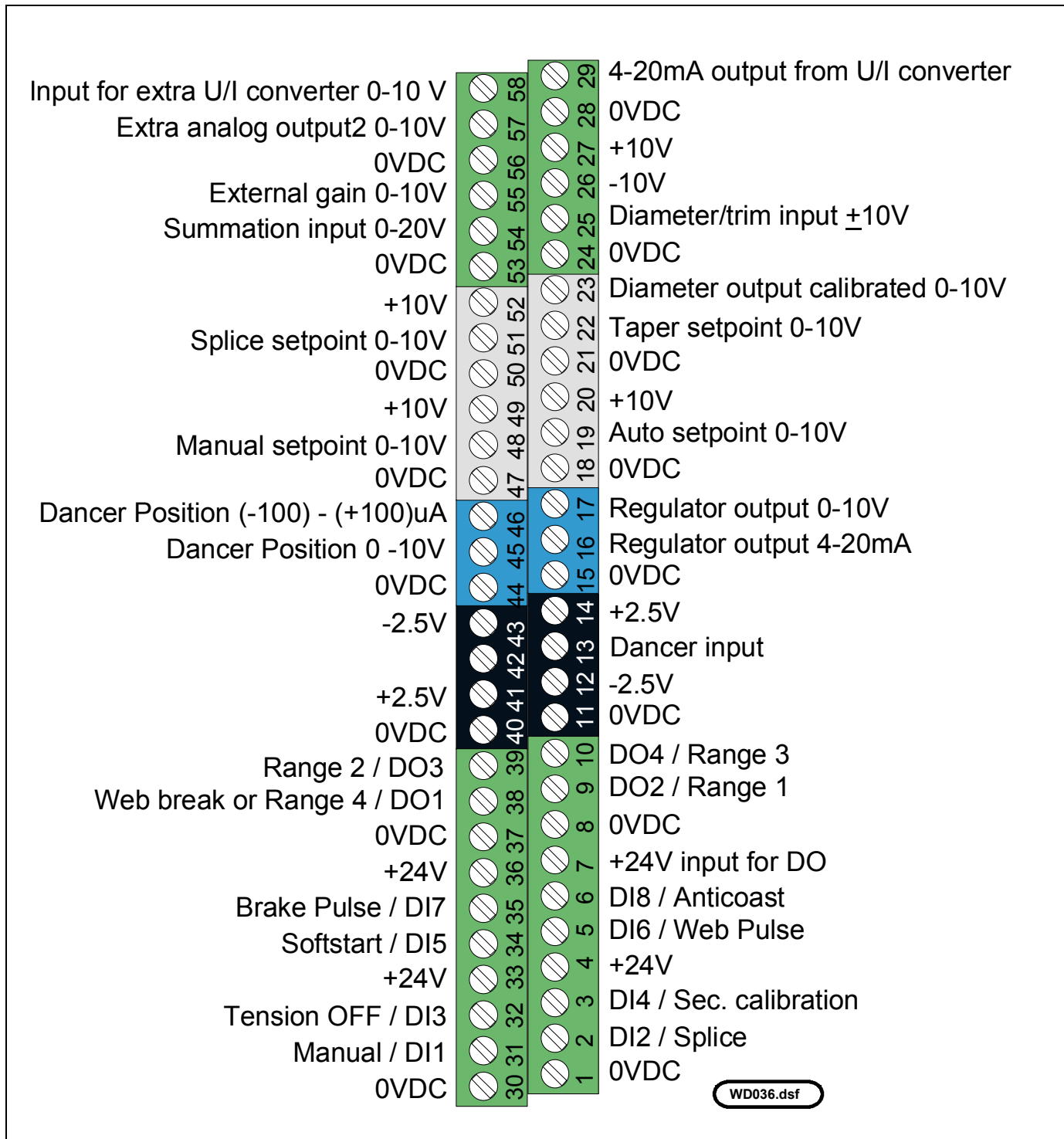

Note: jumpers that connect terminals 4 and 7 and 57 and 55, and which are shipped with the controller, do not appear in the diagram above.

3.6 Basic Wiring Instructions

3.6.1 Installation: Dancer Potentiometer

The following terminals are for dancer potentiometer connections. The standard dancer potentiometer from Montalvo is delivered with a cable. The other end must be wired into the terminal block of the circuit board.

Terminal	Connection
12	-2.5 V Supply
13	Dancer Input
14	+2.5 V Supply

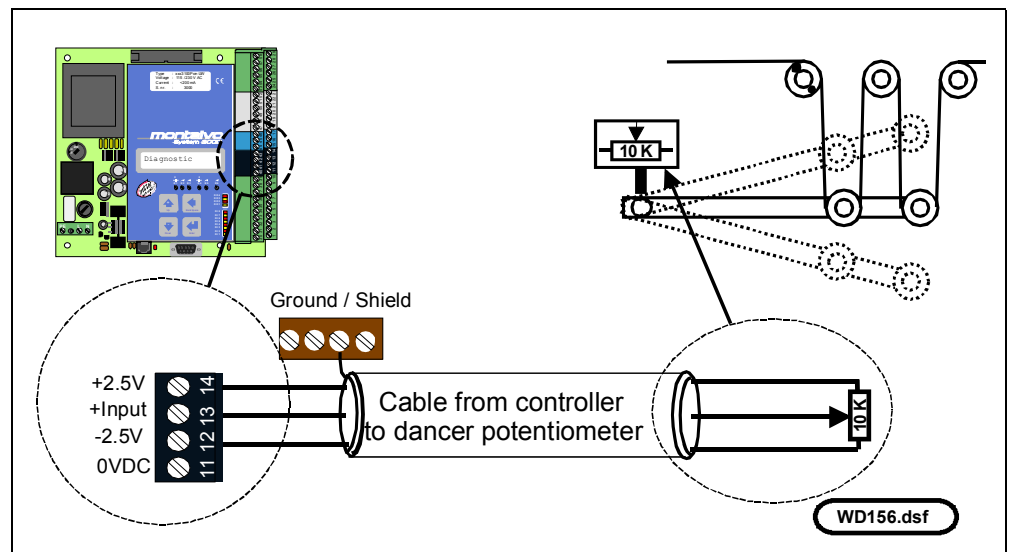

3.6.2 Installation: Regulated Output

15 0VDC	Regulated voltage or current signal common. Connects to input ground of the converter.
16 Regulated Current	Regulated 4 – 20 mA current signal to an I/P or other converter.
17 Regulated Voltage	Regulated 0 - 10 V output. Could be used for a 0 – 10V I/P or other converter. Can control motor drives operating in the torque mode. Maximum load = 5 mA.
4, 33, 36 = +24 V Supply	Unregulated 22 to 28 volt DC supply for external use. Maximum load 350 mA.
1, 8, 11, 15, 18, 21, 24, 28, 30, 37, 40, 44, 47, 50, 53, 56 = 0VDC	Common for signal (GND) and contact inputs and outputs

Wiring Diagram for I/P Converter and P-3000 (signal=4-20 mA)

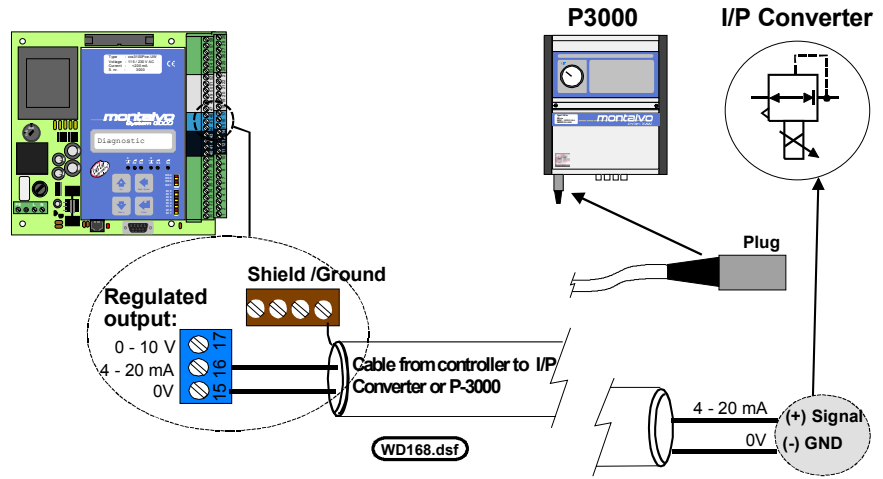

Wiring Diagram for I/P Converter and P-3000ce (signal=4-20 mA and 24 V supply)

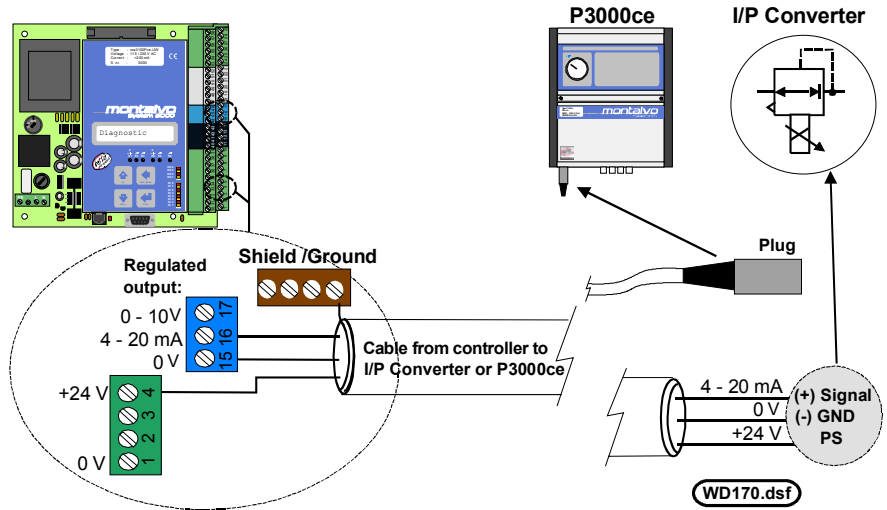

3.6.3 Connecting VAC Power Supply

The controller must be supplied with a 115/230 VAC power supply. Set the voltage selector switch in the correct position. For actual voltage, plug in the correct fuse.

L	Supply Voltage
N	Supply Voltage
PE	Ground

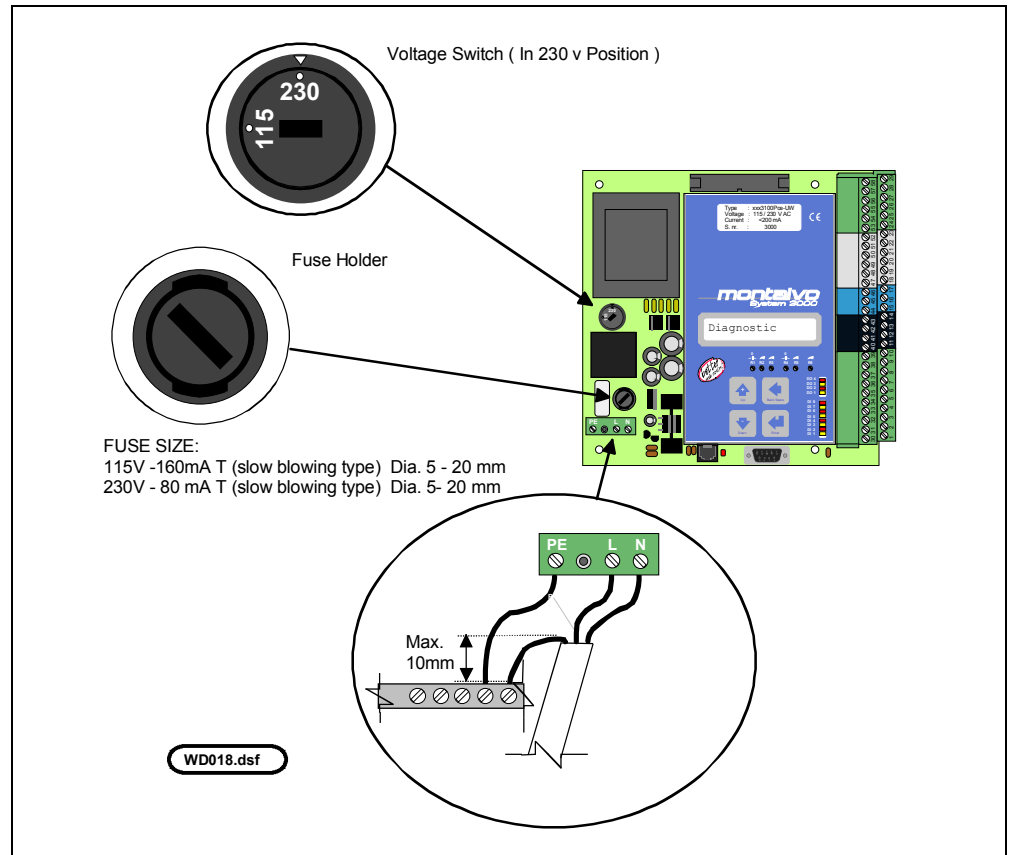

- Diagnostic
- Password
- Setup Menu
 - Mode Menu
 - Run Mode
 - Amplifier
 - Regulator Menu
 - Gain Min.
 - Gain Max.
 - Gain Mid.
 - Sys. Gain
 - P Level
 - D Level
 - Gain Src
 - Softs Menu**
 - Start Out
 - Softs Lev.**
 - Softs Time**
 - Hold Level**
 - Anti Menu
 - Anti.Src.
 - Anti Max
 - Anti Min
 - Anti Slope
 - Splice Menu
 - Splice Src
 - Splice Del
 - Splice Lev
 - Splice Tim
 - WebBr Menu
 - Webbr Lev.
 - Webbr Time
 - Range Exp.
 - RE Source
 - Ranges
 - Start No.
 - Dn Level
 - Up Level
 - Range Time
 - Brake Menu
 - Range Dia Menu
 - Dia. Menu
 - Diamet.Src
 - P/Rev Roll
 - mm/Pulse
 - Min Diam.
 - Max Diam.
 - Fac. Diam
 - DF AutoSet
 - New Roll D
 - Diameter
 - Com Menu(optional)

3.7 Digital Input: Standard Functions

Note: Set [Password] to 5 to access setup menu.

3.7.1 Softstart (Terminal 34)

This input has two purposes:

- To stop the regulator when the machine is not running (hold mode).
- To give the machine a soft startup.

When machine is running and this input signal is activated, the output level will be stored. This level will then be used for [Hold Level] and for the next startup.

In HOLD MODE, output is at a constant [Hold Level]. To keep the roll in the same position in hold mode, hold level must be raised above stored level, typically by 20 to 50%.

To compensate for roll inertia at next startup, the output must be reduced with a percentage of the stored level (typically 15 to 25%).

Machine is stopping	<p>When this input is activated by 24 VDC, the controller switches to STOP MODE.</p> <p>In STOP MODE the controller is still regulating until the time [Softs Time] has elapsed.</p>
Machine has ramped to stop	<p>When time has elapsed, controller changes to HOLD MODE.</p> <p>In HOLD MODE controller is not regulating and the desired output is set to a constant level = [Hold Level]. ([Hold Level] = Stored level + %).</p>
Machine is starting	<p>When input is deactivated by removing ± 24 VDC, output will change to softstart level [Softs Lev.] and the regulator will begin to regulate from that level.</p> <p>([Softs Lev.] = Stored level -%).</p>

Cycles

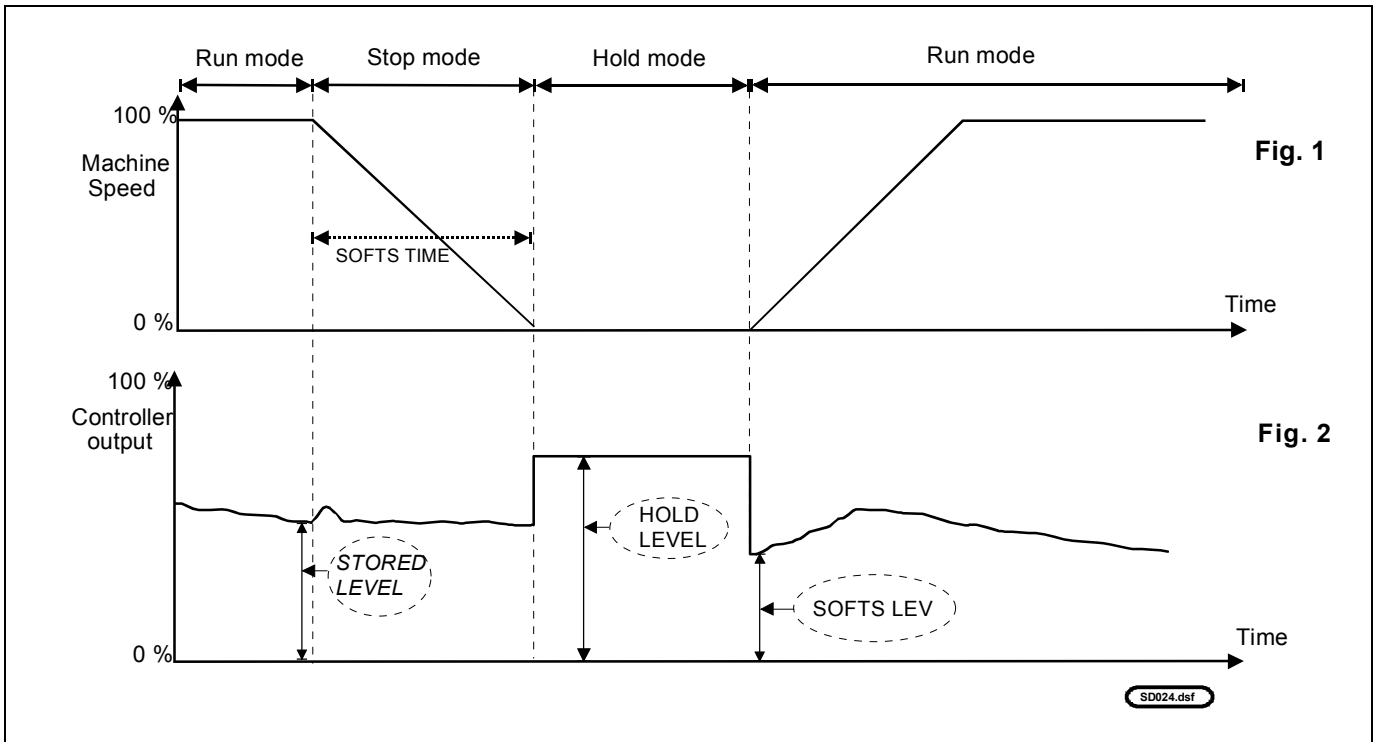

Electrical Wiring

Below is a typical example of connecting the zero speed or stop signal.

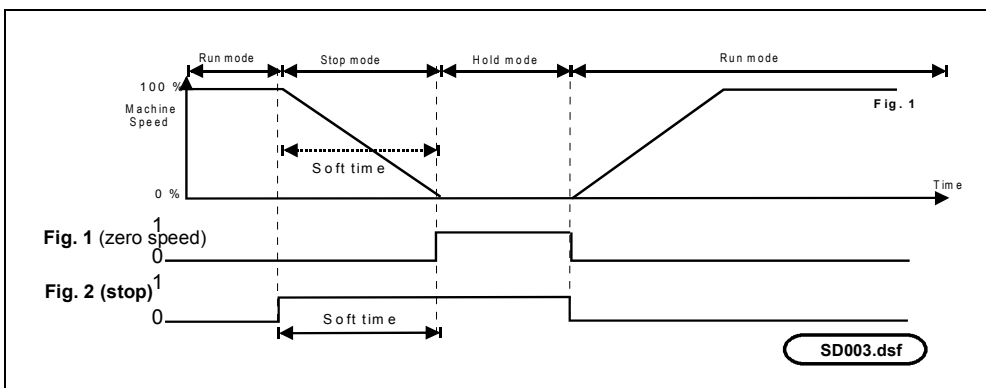
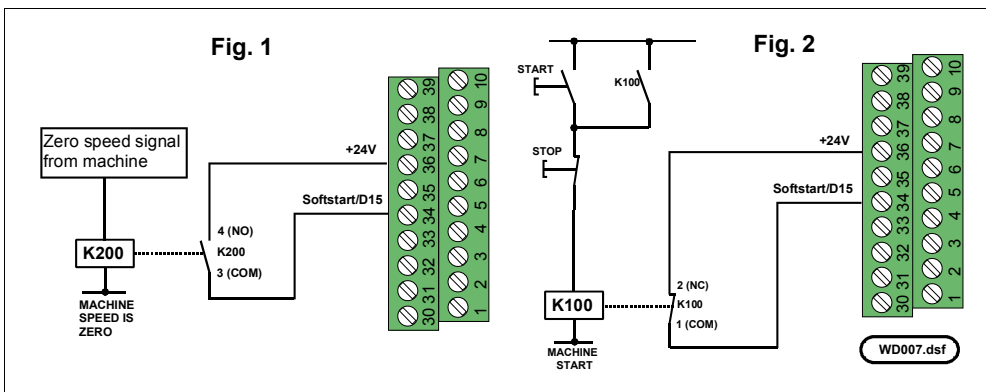

Diagnostic
 Password
 Setup Menu
 Mode Menu
 Run Mode
 Amplifier
 Regulator Menu
 Gain Min.
 Gain Max.
 Gain Mid.
 Sys. Gain
 P Level
 D Level
 Gain Src
Softs Menu
 Start Out
 Softs Lev.
 Softs Time
 Hold Level
 Anti Menu
 Anti.Src.
 Anti Max
 Anti Min
 Anti Slope
 Splice Menu
 Splice Src
 Splice Del
 Splice Lev
 Splice Tim
 WebBr Menu
 Webbr Lev.
 Webbr Time
 Range Exp.
 RE Source
 Ranges
 Start No.
 Dn Level
 Up Level
 Range Time
 Brake Menu
 Range Dia Menu
 Dia. Menu
 Diamet.Src
 P/Rev Roll
 mm/Pulse
 Min Diam.
 Max Diam.
 Fac. Diam
 DF AutoSet
 New Roll D
 Diameter
 Com Menu(optional)

Parameter Setting and Adjustment

1. [Start Out] (Starting output level)

[Start out] is the output level with which controller starts when tension is switched on. This output is applied in three instances: 1) after power-up, and 2) at tension on.

To set the correct value:

- a) Install a roll with 75% maximum diameter.
- b) Start machine and run it at a slow speed. Note output level when dancer has become steady.

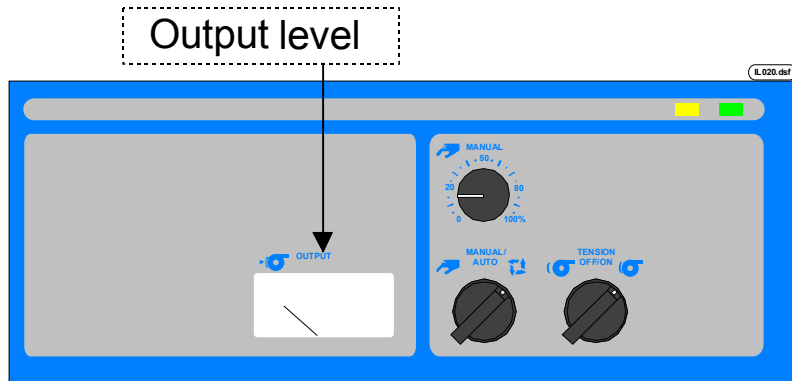

Note: Stop machine and increase or decrease the [Start out] parameter to the level noted in step b). To see the new output level after changing the [Start out] parameter, switch tension off and then on again.

2. [Softs Lev.] (Soft start level)

When the softstart signal goes low (0VDC), output changes to a percentage (%) of the stored level. This percentage is set up in the following parameter.

To set the correct level:

- a) Start machine at slow speed and stop after approximately 30 seconds.
- b) Start machine again.
- c) Note dancer reaction.
- d) If dancer rises, decrease [Softs Lev.]; if dancer drops, increase [Softs Lev.].
- e) If adjustment in d) has been made, return to step b).

Diagnostic
 Password
 Setup Menu
 Mode Menu
 Run Mode
 Amplifier
 Regulator Menu
 Gain Min.
 Gain Max.
 Gain Mid.
 Sys. Gain
 P Level
 D Level
 Gain Src
Softs Menu
 Start Out
 Softs Lev.
Softs Time
Hold Level
 Anti Menu
 Anti.Src.
 Anti Max
 Anti Min
 Anti Slope
 Splice Menu
 Splice Src
 Splice Del
 Splice Lev
 Splice Tim
 WebBr Menu
 Webbr Lev.
 Webbr Time
 Range Exp.
 RE Source
 Ranges
 Start No.
 Dn Level
 Up Level
 Range Time
 Brake Menu
 Range Dia Menu
 Dia. Menu
 Diamet.Src
 P/Rev Roll
 mm/Pulse
 Min Diam.
 Max Diam.
 Fac. Diam
 DF AutoSet
 New Roll D
 Diameter
 Com Menu(optional)

3. [Softs Time] (Time delay to stop)

If a stop signal is used and there is a delay between the time that the stop signal has been activated and the time that the machine reaches zero speed, enter the time as follows.

To set the correct time:

- a) Run machine at maximum speed.
- b) Measure time from activation of stop to zero speed.
- c) Enter this time + 0.2 seconds in this parameter.

Note: *If this time is longer than 10 seconds, use a zero speed signal.*

Enter a short time when using a zero speed signal. The minimum value is 0.1 seconds.

4. [Hold Level] (Hold level in stop mode)

When **Softstart** signal is set high (Active high = +24 VDC), the controller stores the output level, but continues to regulate until the **[Softs Time]** has run out. If the time is set to the minimum value of 0.1 seconds, the output will change to **[Hold Level]** after 0.1 seconds. (**[Hold Level]** = stored level +%) If a longer time is set up, the output will change after that time. In "HOLD MODE" the output is at a constant hold level.

To keep the roll in the same position in **HOLD MODE**, raise the stored level by the percentage (%) set in Hold Level.

Typical **[Hold Level]** = Stored level + 50%, **FACTORY setting.**

Example of the output level in HOLD MODE:

- **Hold Mode Menu: Hold Level 100%** => Stored level
- **Hold Mode Menu: Hold Level 150%** => Stored level + 50%

- Diagnostic
- Password
- Setup Menu
 - Mode Menu
 - Run Mode
 - Amplifier
 - Regulator Menu
 - Gain Min.
 - Gain Max.
 - Gain Mid.
 - Sys. Gain
 - P Level
 - D Level
 - Gain Src
 - Softs Menu
 - Start Out
 - Softs Lev.
 - Softs Time
 - Hold Level
 - Anti Menu**
 - Anti.Src.**
 - Anti Max**
 - Anti Min**
 - Anti Slope**
 - Splice Menu
 - Splice Src
 - Splice Del
 - Splice Lev
 - Splice Tim
 - WebBr Menu
 - Webbr Lev.
 - Webbr Time
 - Range Exp.
 - RE Source
 - Ranges
 - Start No.
 - Dn Level
 - Up Level
 - Range Time
 - Brake Menu
 - Range Dia Menu
 - Dia. Menu
 - Diamet.Src
 - P/Rev Roll
 - mm/Pulse
 - Min Diam.
 - Max Diam.
 - Fac. Diam
 - DF AutoSet
 - New Roll D
 - Diameter
 - Com Menu (optional)

3.7.2 Anticoast (TERMINAL 6)

Use this signal if machine has a fast stop function or if it stops with a short rampdown time.

To prevent a drop in dancer position, activate signal exactly when the machine begins to ramp down (see Fig. 1).

Fig. 2 shows how the dancer will drop if this signal is not used.

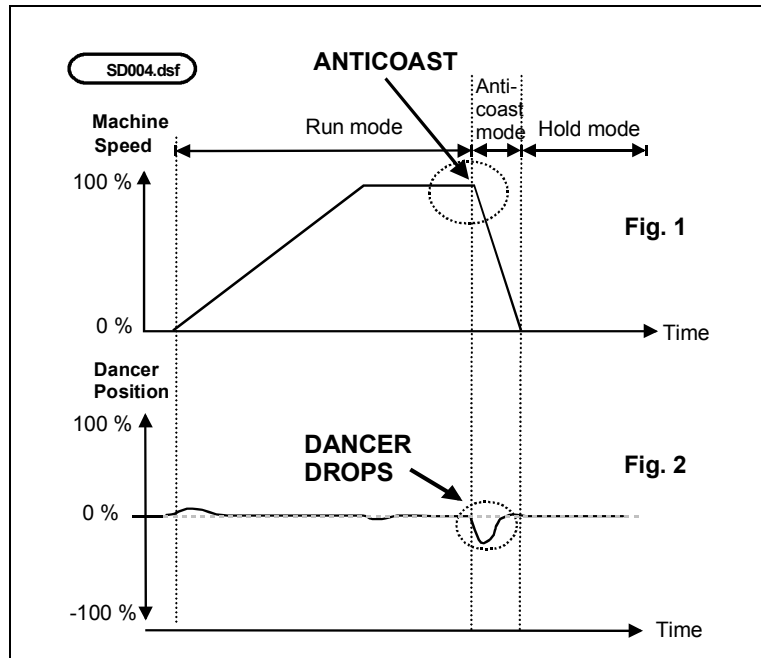

Stop signal is activated

When input is activated by 24 VDC, output increases to a higher level and then starts to regulate again. The level is set by the anticoast level parameter.

Anticoast is factory-set to use **Source=OUTPUT**.

Possible sources for anticoast:

[OUTPUT]	The torque required for fast stop is calculated internally by the controller from the setpoint and the output. The result is a calculated diameter that can be scaled by an adjustable factor that fits the machine's actual rampdown time.
[DIAMETER]	In some applications, the correct diameter cannot be calculated from setpoint and output. In such instances, diameter should be chosen as source.

Examples for which diameter source is best when production:

- Requires large rolls and low tension
- Uses a great variety of materials

Note: set up and adjust diameter parameters in the diameter menu.

- Diagnostic
- Password
- Setup Menu
 - Mode Menu
 - Run Mode
 - Amplifier
 - Regulator Menu
 - Gain Min.
 - Gain Max.
 - Gain Mid.
 - Sys. Gain
 - P Level
 - D Level
 - Gain Src
 - Softs Menu
 - Start Out
 - Softs Lev.
 - Softs Time
 - Hold Level
 - Anti Menu**
 - Anti.Src.**
 - Anti Max**
 - Anti Min**
 - Anti Slope**
 - Splice Menu
 - Splice Src
 - Splice Del
 - Splice Lev
 - Splice Tim
 - WebBr Menu
 - Webbr Lev.
 - Webbr Time
 - Range Exp.
 - RE Source
 - Ranges
 - Start No.
 - Dn Level
 - Up Level
 - Range Time
 - Brake Menu
 - Range Dia Menu
 - Dia. Menu
 - Diamet.Src
 - P/Rev Roll
 - mm/Pulse
 - Min Diam.
 - Max Diam.
 - Fac. Diam
 - DF AutoSet
 - New Roll D
 - Diameter
 - Com Menu (optional)

Electrical Wiring

Below is a typical example of connecting the fast stop.

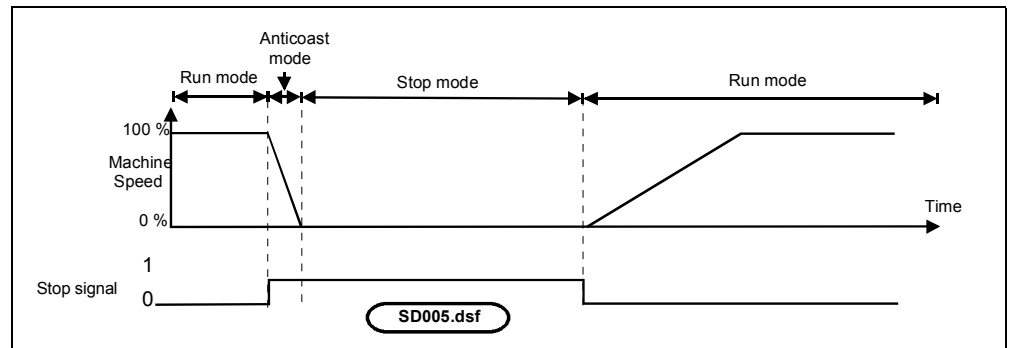
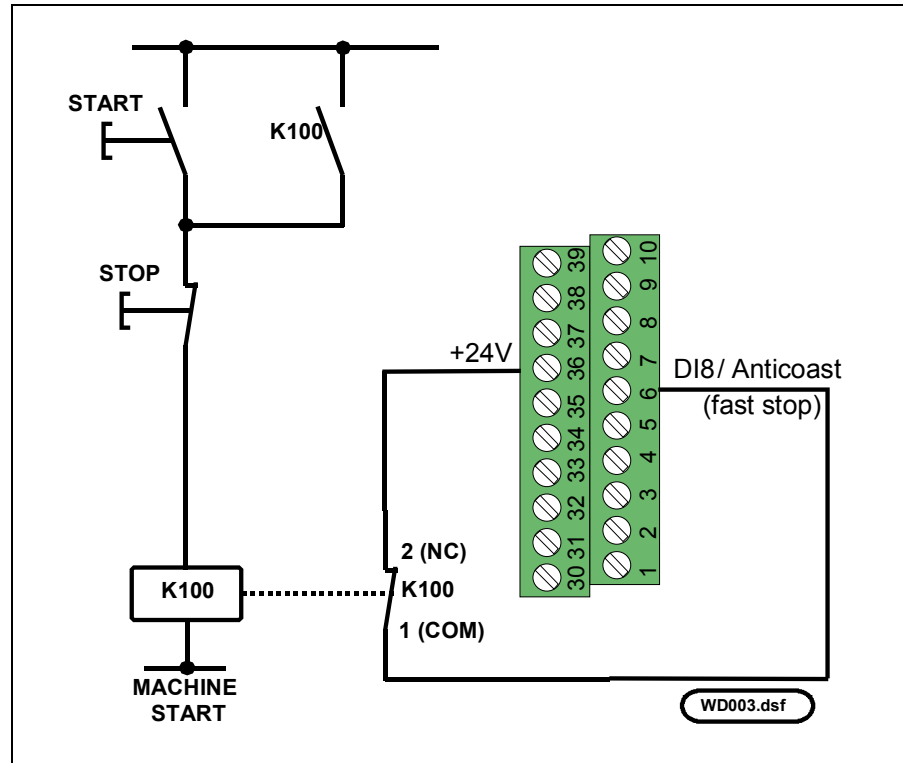

Diagnostic
Password
Setup Menu
 Mode Menu
 Run Mode
 Amplifier
 Regulator Menu
 Gain Min.
 Gain Max.
 Gain Mid.
 Sys. Gain
 P Level
 D Level
 Gain Src
 Softs Menu
 Start Out
 Softs Lev.
 Softs Time
 Hold Level
Anti Menu
 Anti.Src.
 Anti Max
 Anti Min
 Anti Slope
 Splice Menu
 Splice Src
 Splice Del
 Splice Lev
 Splice Tim
 WebBr Menu
 Webbr Lev.
 Webbr Time
 Range Exp.
 RE Source
 Ranges
 Start No.
 Dn Level
 Up Level
 Range Time
 Brake Menu
 Range Dia Menu
 Dia. Menu
 Diamet.Src
 P/Rev Roll
 mm/Pulse
 Min Diam.
 Max Diam.
 Fac. Diam
 DF AutoSet
 New Roll D
 Diameter
 Com Menu(optional)

Parameter Setting and Adjustment

1. [Anti.Src.] (Anti coast source)

Set up the source for the anticoast under the following parameters:

[Anti.Src.=OUTPUT]	Calculate the torque used for anticoast by multiplying the output level by the adjustable factor.
[Anti.Src.=DIA.]	The torque required for anticoast is calculated internally by the controller from the actual diameter and output. The result is then scaled by an adjustable factor that fits the machine's actual rampdown time.

2. [Anti Max] (Anticoast maximum level)

Set up maximum necessary level for the torque at anticoast with this parameter. See graph below.

Anti Max

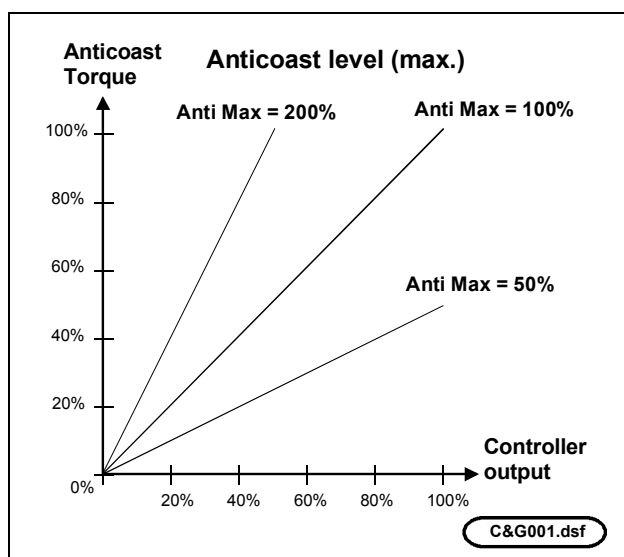

To set the correct value:

- Install a small roll. Apply about 50% load/weight onto the dancer.
- Start machine and run it at maximum speed.
- When dancer has stabilized for 10 seconds, stop the machine with the function that activates the fast stop signal.
- Note the dancer reaction.
- Decrease [Anti Max] if dancer rises; increase if dancer drops.
- If adjustment in step e) is made, return to step b).

Diagnostic
 Password
 Setup Menu
 Mode Menu
 Run Mode
 Amplifier
 Regulator Menu
 Gain Min.
 Gain Max.
 Gain Mid.
 Sys. Gain
 P Level
 D Level
 Gain Src
 Softs Menu
 Start Out
 Softs Lev.
 Softs Time
 Hold Level
Anti Menu
Anti.Src.
Anti Max
Anti Min
Anti Slope
 Splice Menu
 Splice Src
 Splice Del
 Splice Lev
 Splice Tim
 WebBr Menu
 Webbr Lev.
 Webbr Time
 Range Exp.
 RE Source
 Ranges
 Start No.
 Dn Level
 Up Level
 Range Time
 Brake Menu
 Range Dia Menu
 Dia. Menu
 Diamet.Src
 P/Rev Roll
 mm/Pulse
 Min Diam.
 Max Diam.
 Fac. Diam
 DF AutoSet
 New Roll D
 Diameter
 Com Menu (optional)

3. [Anti Min] (Anticoast minimum level)

Set up minimum necessary level for torque at anticoast with this parameter. See graph below.

Anti Min

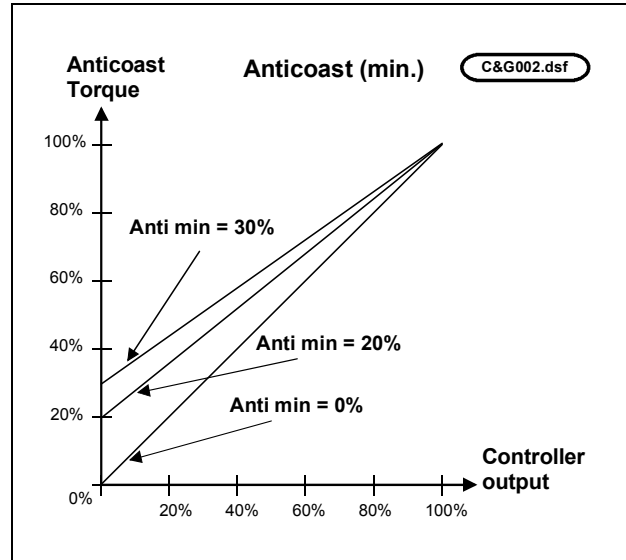

To set the correct value:

- a) Install a small roll.
- b) Start machine and run it at *maximum* speed.
- c) When dancer has stabilized for 10 seconds, stop the machine with the function that activates the fast stop signal.
- d) Note the dancer reaction.
- e) Decrease [Anti Min] if dancer rises; increase if dancer drops.
- f) If adjustment in step e) is made, return to step b).

Diagnostic
 Password
 Setup Menu
 Mode Menu
 Run Mode
 Amplifier
 Regulator Menu
 Gain Min.
 Gain Max.
 Gain Mid.
 Sys. Gain
 P Level
 D Level
 Gain Src
 Softs Menu
 Start Out
 Softs Lev.
 Softs Time
 Hold Level
 Anti Menu
 Anti.Src.
 Anti Max
 Anti Min
 Anti Slope
 Splice Menu
 Splice Src
 Splice Del
 Splice Lev
 Splice Tim
 WebBr Menu
 Webbr Lev.
 Webbr Time
 Range Exp.
 RE Source
 Ranges
 Start No.
 Dn Level
 Up Level
 Range Time
 Brake Menu
 Range Dia Menu
 Dia. Menu
 Diamet.Src
 P/Rev Roll
 mm/Pulse
 Min Diam.
 Max Diam.
 Fac. Diam
 DF AutoSet
 New Roll D
 Diameter
 Com Menu(optional)

4. [Anti Slope] (Anticoast Slope)

This parameter sets up the correct slope for the torque at anticoast. See curve graph below.

Anti Slope

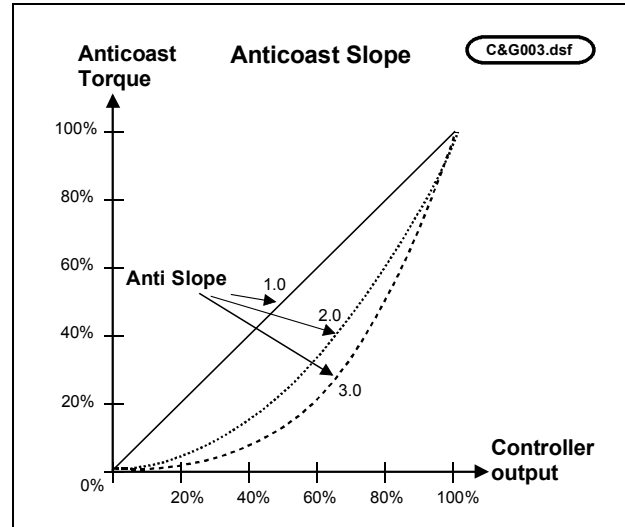

To set the correct value:

- a) Install a roll approximately 33% in diameter.
- b) Start machine and run at maximum speed.
- c) When dancer has stabilized for 10 seconds, stop the machine with the function that activates the fast stop signal.
- d) Note the dancer reaction.
- e) Increase [Anti Slope] if dancer rises; decrease if dancer drops.
- f) If adjustment in step e) is made, return to step b).

Diagnostic
 Password
 Setup Menu
 Mode Menu
 Run Mode
 Amplifier
 Regulator Menu
 Gain Min.
 Gain Max.
 Gain Mid.
 Sys. Gain
 P Level
 D Level
 Gain Src
 Softs Menu
 Start Out
 Softs Lev.
 Softs Time
 Hold Level
 Anti Menu
 Anti.Src.
 Anti Max
 Anti Min
 Anti Slope
Splice Menu
 Splice Src
 Splice Del
 Splice Lev
 Splice Tim
 WebBr Menu
 Webbr Lev.
 Webbr Time
 Range Exp.
 RE Source
 Ranges
 Start No.
 Dn Level
 Up Level
 Range Time
 Brake Menu
 Range Dia Menu
 Dia. Menu
 Diamet.Src
 P/Rev Roll
 mm/Pulse
 Min Diam.
 Max Diam.
 Fac. Diam
 DF AutoSet
 New Roll D
 Diameter
 Com Menu (optional)

3.7.3 Splice (DI2) (TERMINAL 2)

The splice function controls the regulator in splice sequence. The following sequence diagram shows a flying splice.

1. New roll is ready and in splice position when operator activates splice sequence. (Typically, new roll will be accelerated up to web speed.)
2. Splice arm moves down; new roll is spliced onto running web.
3. Knife cuts web from the old roll.
4. Knife and splice arm retract. Splice is finished.

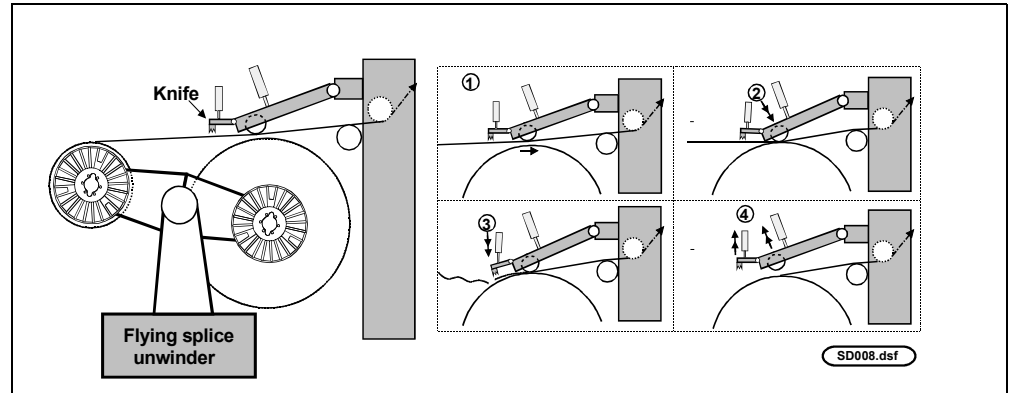

In a splice sequence, output level must change from the regulated output level on the old (or expiring) roll to a new output level on the new roll. The output level on the expiring roll will normally be low, while on the new roll the output must change to a much higher level.

If diameter size of a new roll is about the same at every splice, the splice level will always be the same. If the diameter that is being spliced varies a great degree, the splice level will also vary every time. In a standard application, the splice level is set in a software parameter that is fixed at the same level for every splice. As an **option**, the splice level can be set up either from an external setpoint or from a potentiometer on the front of the cabinet version. The option should be used in cases in which splice levels vary to a great degree.

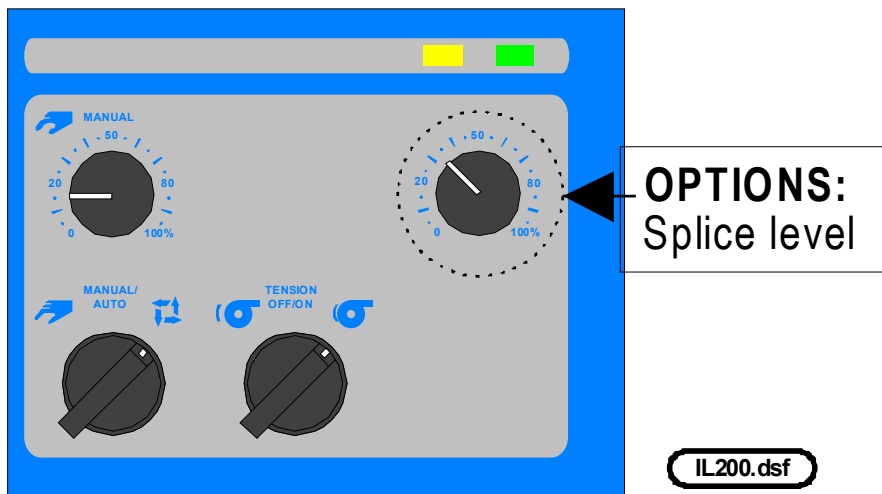

- Diagnostic
- Password
- Setup Menu
 - Mode Menu
 - Run Mode
 - Amplifier
 - Regulator Menu
 - Gain Min.
 - Gain Max.
 - Gain Mid.
 - Sys. Gain
 - P Level
 - D Level
 - Gain Src
 - Softs Menu
 - Start Out
 - Softs Lev.
 - Softs Time
 - Hold Level
 - Anti Menu
 - Anti.Src.
 - Anti Max
 - Anti Min
 - Anti Slope
- Splice Menu**
 - Splice Src**
 - Splice Del**
 - Splice Lev**
 - Splice Tim**
- WebBr Menu
 - Webbr Lev.
 - Webbr Time
- Range Exp.
 - RE Source
 - Ranges
 - Start No.
 - Dn Level
 - Up Level
 - Range Time
- Brake Menu
- Range Dia Menu
- Dia. Menu
 - Diamet.Src
 - P/Rev Roll
 - mm/Pulse
 - Min Diam.
 - Max Diam.
 - Fac. Diam
 - DF AutoSet
 - New Roll D
 - Diameter
- Com Menu(optional)

Electrical Wiring

Below is an example of how to connect the splice signal. Typically a knife signal is used.

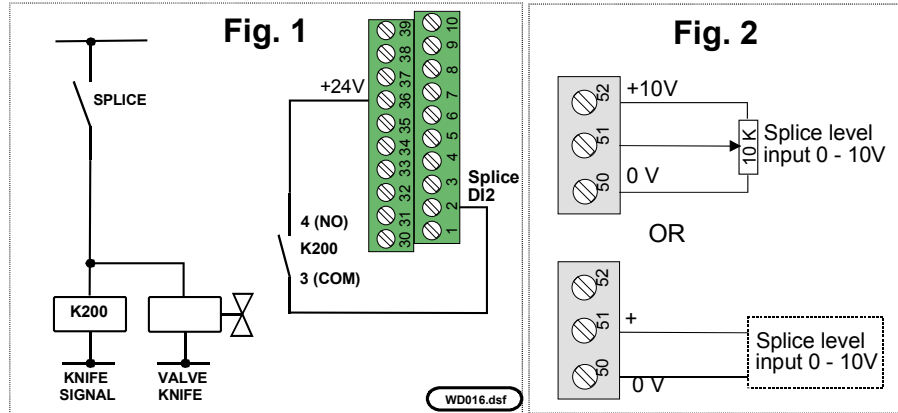

Optional: Wire external splice level according to Fig. 2, if needed.

In splice mode the regulator is held at a constant level [Splice Lev] for a time [Splice Tim], and then starts regulating again from that level (see the following sequence diagram). **Optional:** A delay between the knife signal and the cutting of the web can be set up in the parameter [Splice Del], if required.

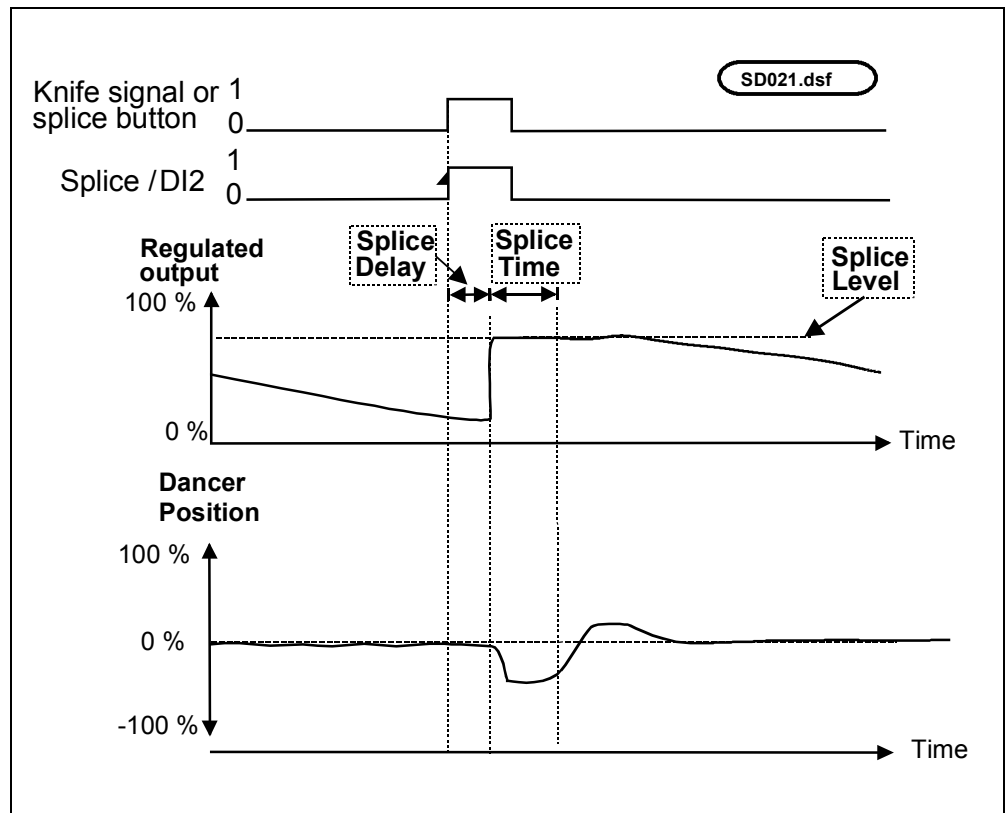

Diagnostic
 Password
 Setup Menu
 Mode Menu
 Run Mode
 Amplifier
 Regulator Menu
 Gain Min.
 Gain Max.
 Gain Mid.
 Sys. Gain
 P Level
 D Level
 Gain Src
 Softs Menu
 Start Out
 Softs Lev.
 Softs Time
 Hold Level
 Anti Menu
 Anti.Src.
 Anti Max
 Anti Min
 Anti Slope
Splice Menu
 Splice Src
 Splice Del
 Splice Lev
 Splice Tim
 WebBr Menu
 Webbr Lev.
 Webbr Time
 Range Exp.
 RE Source
 Ranges
 Start No.
 Dn Level
 Up Level
 Range Time
 Brake Menu
 Range Dia Menu
 Dia. Menu
 Diamet.Src
 P/Rev Roll
 mm/Pulse
 Min Diam.
 Max Diam.
 Fac. Diam
 DF AutoSet
 New Roll D
 Diameter
 Com Menu (optional)

Parameter Setting and Adjustment

1. [Splice Src] (Splice source)

The source for the splice level must be set up.

[NONE]	Set up if splice is not used .
[S. Lev]	(Local source) With [s. Lev] as the source, the splice level is being set up in a menu parameter. Choose this source if the diameter of the new roll is about the same at every splice.
[ANALOG]	(Analog source) With [ANALOG] as source, the splice level comes from an analog signal (0-10V). The analog signal can either be wired on terminal 51, or come from a potentiometer on the front panel in the cabinet version (see diagram below). This source is best for large changes in the diameter of the new roll.

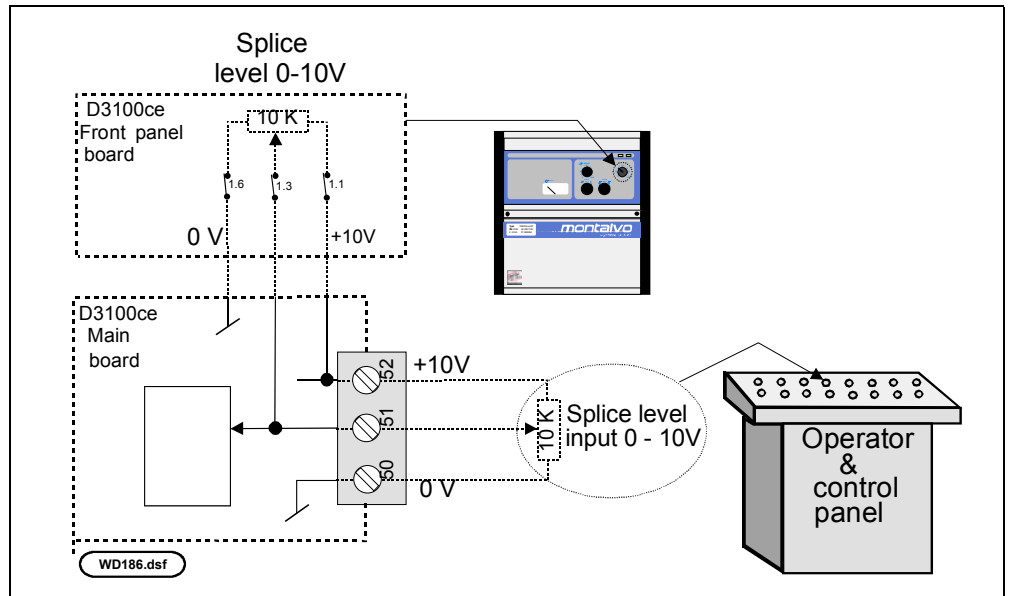

Note: splice level from the front of the cabinet and external splice level cannot be used at the same time.

2. [Splice Del] (Splice delay)

Set up the delay between activation of the knife signal and the cutting of the web with this parameter.

3. [S. Lev] (Level from menu parameter)

[Splice Src=S. Lev.]	Set up the splice level in this parameter. A new output level is required when the knife cuts the web. This level depends upon the diameter of the new roll. In cases in which new rolls are approximately identical in diameter, the splice level can be set at a constant value.
-----------------------------	--

Diagnostic
 Password
 Setup Menu
 Mode Menu
 Run Mode
 Amplifier
 Regulator Menu
 Gain Min.
 Gain Max.
 Gain Mid.
 Sys. Gain
 P Level
 D Level
 Gain Src
 Softs Menu
 Start Out
 Softs Lev.
 Softs Time
 Hold Level
 Anti Menu
 Anti.Src.
 Anti Max
 Anti Min
 Anti Slope
 Splice Menu
 Splice Src
 Splice Del
 Splice Lev
 Splice Tim
 WebBr Menu
 Webbr Lev.
 Webbr Time
 Range Exp.
 RE Source
 Ranges
 Start No.
 Dn Level
 Up Level
 Range Time
 Brake Menu
 Range Dia Menu
 Dia. Menu
 Diamet.Src
 P/Rev Roll
 mm/Pulse
 Min Diam.
 Max Diam.
 Fac. Diam
 DF AutoSet
 New Roll D
 Diameter
 Com Menu(optional)

To set the correct value:

- a) Install a roll with maximum diameter.
- b) Start machine at a slow speed. Note output level when dancer has stabilized.

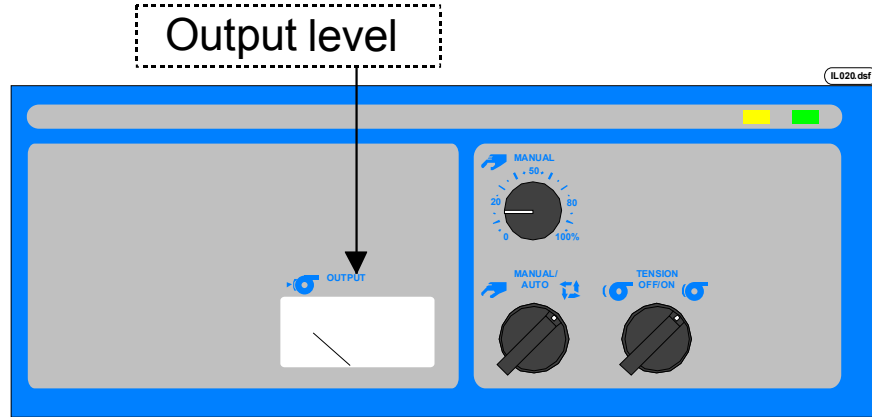

- c) Adjust [Splice Lev] to output noted in step b).

4. Level from analog source

<p>[Splice Src = ANALOG] (Analog Source)</p>	<p>The signal on terminal 51 can either come from the front of the cabinet version or from an analog input signal. 0 to 10 VDC on this analog input will give 0 to 100% output. Once the knife cuts the web, a new output level will be needed. The new output level depends upon the diameter of the new roll.</p>
--	---

To set the correct values:

- a) Install a full roll with the required dancer load/weight.
- b) Start machine at a slow speed. Note output level when dancer has stabilized.
- c) Stop machine and write down diameter and output level. The noted output level should be the correct splice level for this diameter.
- d) Perform steps a to c with different diameters and list them as well.

Production	Dancer Load	Splice level	Diameter
Paper (40 grams/25 lbs.)	(2 Bar) (29 psi)	60%	100%
Paper (40 grams/25 lbs.)	(2 Bar)	45%	75%
Paper (40 grams/25 lbs.)	(2 Bar)	30%	50%
Paper (80 grams/50 lbs.)	(4 Bar)(58 psi)	80%	100%

Diagnostic
 Password
 Setup Menu
 Mode Menu
 Run Mode
 Amplifier
 Regulator Menu
 Gain Min.
 Gain Max.
 Gain Mid.
 Sys. Gain
 P Level
 D Level
 Gain Src
 Softs Menu
 Start Out
 Softs Lev.
 Softs Time
 Hold Level
 Anti Menu
 Anti.Src.
 Anti Max
 Anti Min
 Anti Slope
 Splice Menu
 Splice Src
 Splice Del
 Splice Lev
 Splice Tim
 WebBr Menu
 Webbr Lev.
 Webbr Time
 Range Exp.
 RE Source
 Ranges
 Start No.
 Dn Level
 Up Level
 Range Time
 Brake Menu
 Range Dia Menu
 Dia. Menu
 Diamet.Src
 P/Rev Roll
 mm/Pulse
 Min Diam.
 Max Diam.
 Fac. Diam
 DF AutoSet
 New Roll D
 Diameter
 Com Menu(optional)

5. [Splice Tim] (Splice time)

During this time, output is set to a constant level before returning to automatic regulation. A typical setting for this parameter is about 1.0 seconds.

Checking Splice Settings

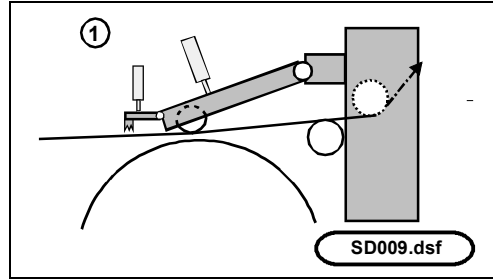

a) Put in a new roll in splice position.

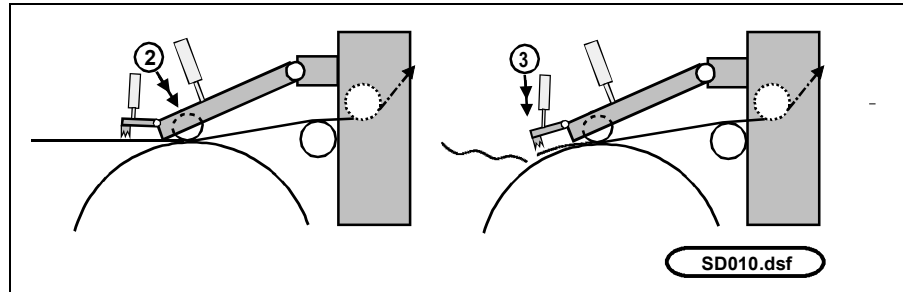

b) Run machine at splice speed, and make a splice. Dancer position should resemble the one represented in Fig. 2 below.

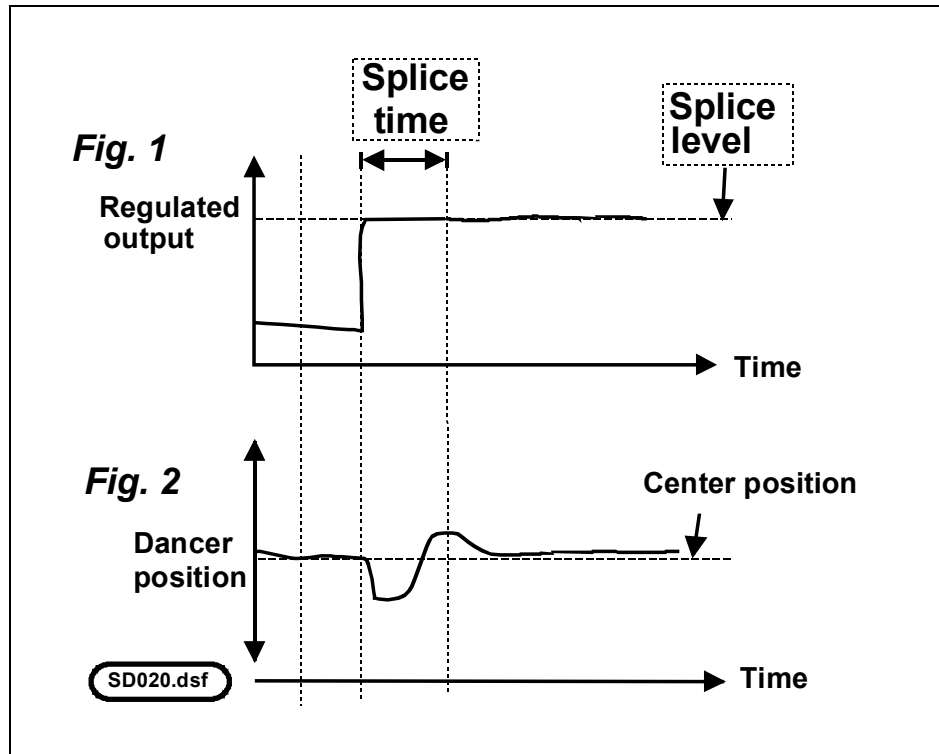

3.7.4 Manual (DI1) (TERMINAL 31)

When activated by a 24 VDC input, the controller switches to the manual mode. Regulated output is set by the potentiometer marked MANUAL. When deactivated, the controller regulates from the manual value.

3.7.5 Tension Off (DI3) (TERMINAL 32)

When activated by a 24 VDC input, the output goes to zero and the regulator is reset. This function is used at roll change. When input goes low, the regulator is set to the new roll parameter (START OUT).

3.8 Analog Signals: Standard Functions

47 0VDC	Connects to the CCW terminal (1) of the MANUAL potentiometer. Use 10 k Ω potentiometer.
48 Manual	0 to 10 volt input corresponding from zero to maximum output in manual mode. Connects to the wiper terminal (2) of the MANUAL potentiometer.
49 10V Reference	Reference voltage applied to the CW terminal (3) of the manual potentiometer. Total maximum load: 5 mA.

50 0VDC	Connects to the CCW terminal (1) of the splice level potentiometer. Use 10 k Ω potentiometer.
51 Splice level	Input for external signal if used to set output during splice mode. A 0 to 10 volt input corresponds from zero to maximum output.
52 10V Reference	Reference voltage applied to CW terminal (3) of the splice level potentiometer. Total maximum load: 5 mA.

44 0VDC	Common for dancer outputs
45 Dancer position, -10 To +10 V	Indicates the dancer position -100 to +100%
46 Dancer position, -100 To +100 μA	Indicates the dancer position -100 to +100%

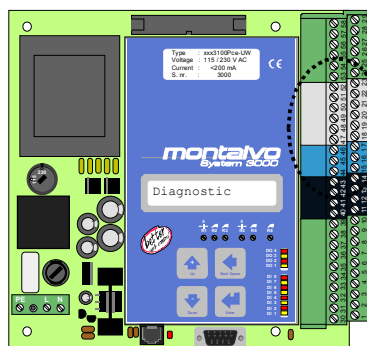

WD162.dsf

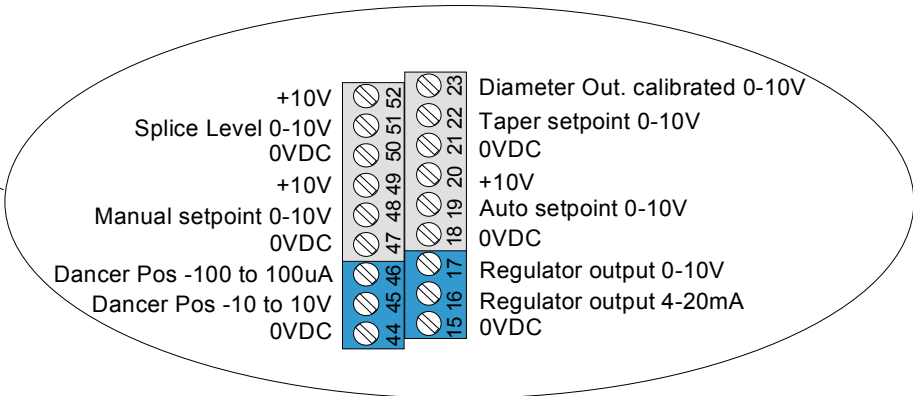

3.9 Input and Output: Special Functions

58 Input 0-10V for Current Converter	Input for voltage to current converter. Converts 0-10V into 0-20mA / 4-20mA, depending on setup.
57 Extra Analog Output2	±10V max 5mA. Used in special applications.
56 0VDC	For extra analog output.
55 External Gain	Input for external gain reference to the regulator. May be input from diameter calculator or other source. For special applications.
54 Summation	Extra summing input to regulator circuit (0-20VDC). Used in intermediate applications where the tachometer signal is connected into the system. The signal must be galvanically isolated. For intermediate and special applications only.
29 Output 0-20mA/4-20mA	Output from voltage to current converter. Converts 0-10V on terminal 58 into 0-20mA/4-20mA, depending on setup.
26 -10 V Reference	Reference supply for external use. -10V max 5mA.
35 Digital Input 6	24 VDC digital input from proximity switch or encoder on brake for diameter calculation. Maximum frequency 80 Hz.
5 Digital Input 5	24 VDC digital input from proximity switch or encoder on main machine for diameter calculation. Maximum frequency 800 Hz.
7 Supply	24 VDC supply input for supply of digital outputs.
8 0VDC	Common for digital outputs 1 & 2.
38 Digital Output 1 (Web Break)	Digital output 24 VDC maximum 100mA.(Can also be used for range expander)
9 Digital Output 2	Digital output 24 VDC maximum 100mA. Normally used for range expander.
37 0VDC	Common for digital output 3 & 4.
39 Digital Output 3	Digital output 24 VDC maximum 100mA. Normally used for range expander.
10 Digital Output 4	Digital output 24 VDC maximum 100mA. Normally used for range expander.

Diagnostic
 Password
 Setup Menu
 Mode Menu
 Run Mode
 Amplifier
 Regulator Menu
 Gain Min.
 Gain Max.
 Gain Mid.
 Sys. Gain
 P Level
 D Level
 Gain Src
 Softs Menu
 Start Out
 Softs Lev.
 Softs Time
 Hold Level
 Anti Menu
 Anti.Src.
 Anti Max
 Anti Min
 Anti Slope
 Splice Menu
 Splice Src
 Splice Del
 Splice Lev
 Splice Tim
WebBr Menu
 Webbr Lev.
 Webbr Time
 Range Exp.
 RE Source
 Ranges
 Start No.
 Dn Level
 Up Level
 Range Time
 Brake Menu
 Range Dia Menu
 Dia. Menu
 Diamet.Src
 P/Rev Roll
 mm/Pulse
 Min Diam.
 Max Diam.
 Fac. Diam
 DF AutoSet
 New Roll D
 Diameter
 Com Menu (optional)

3.10 Web Break

This digital output stops the machine if the web breaks. The output will typically activate a customer-supplied relay that stops the machine (maximum 100 mA load for the digital output).

The web break function is activated 10 seconds after softstart is low (Softstart low = machine started).

This 10-second period allows startup with new rolls when little or no tension is present.

When web break is active, and dancer goes below web break level longer than web break time, output will be activated (i.e., go high). See Fig. 1.

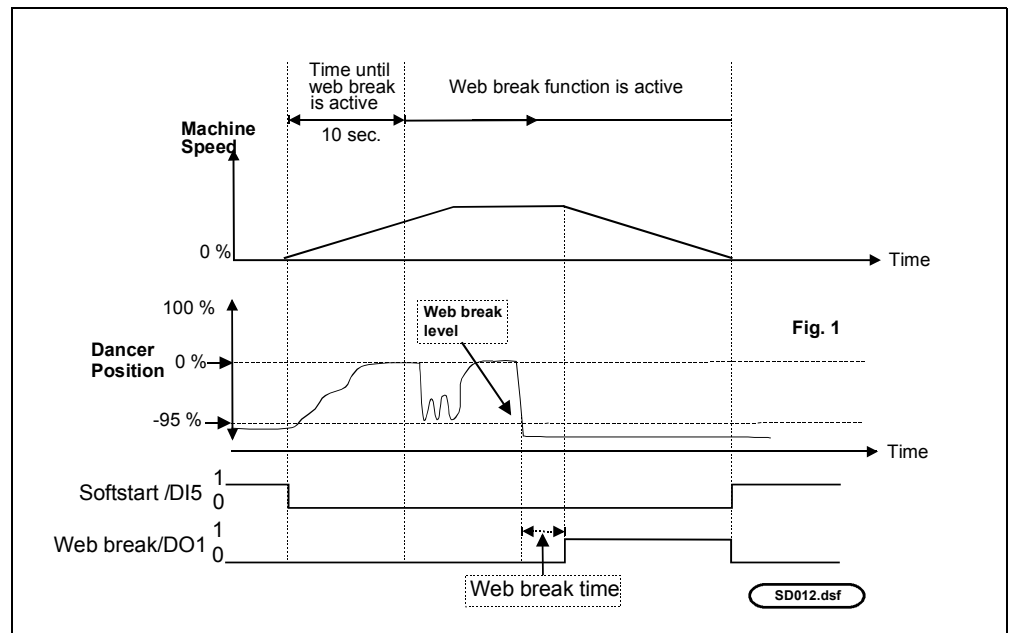

Activation of output during web break

Diagnostic
 Password
 Setup Menu
 Mode Menu
 Run Mode
 Amplifier
 Regulator Menu
 Gain Min.
 Gain Max.
 Gain Mid.
 Sys. Gain
 P Level
 D Level
 Gain Src
 Softs Menu
 Start Out
 Softs Lev.
 Softs Time
 Hold Level
 Anti Menu
 Anti.Src.
 Anti Max
 Anti Min
 Anti Slope
 Splice Menu
 Splice Src
 Splice Del
 Splice Lev
 Splice Tim
WebBr Menu
 Webbr Lev.
 Webbr Time
 Range Exp.
 RE Source
 Ranges
 Start No.
 Dn Level
 Up Level
 Range Time
 Brake Menu
 Range Dia Menu
 Dia. Menu
 Diamet.Src
 P/Rev Roll
 mm/Pulse
 Min Diam.
 Max Diam.
 Fac. Diam
 DF AutoSet
 New Roll D
 Diameter
 Com Menu(optional)

Electrical Wiring

Below is a typical example of how to connect a web break.

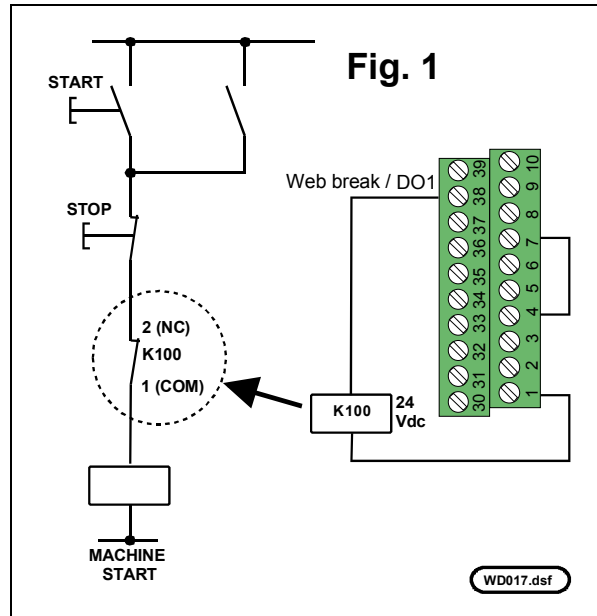

Parameter Setting and Adjustment

To set up parameters in the web break menu, go to web break menu under the setup menu:

1. [Webbr Lev] (Web break level)

Dancer position below this level will activate output after the web break time. The factory setting of -95% is correct for most applications.

2. [Webbr. Time] (Web break time)

This is the time that the dancer has to be under the web break level before output is activated (or goes high).

To adjust this parameter, the time should be:

- **long enough** so that small dancer drops do not stop the machine.
- **short enough** to prevent minimum material waste before stop.

Diagnostic
Password
Setup Menu
 Mode Menu
 Run Mode
 Amplifier
 Regulator Menu
 Gain Min.
 Gain Max.
 Gain Mid.
 Sys. Gain
 P Level
 D Level
 Gain Src
 Softs Menu
 Start Out
 Softs Lev.
 Softs Time
 Hold Level
 Anti Menu
 Anti.Src.
 Anti Max
 Anti Min
 Anti Slope
 Splice Menu
 Splice Src
 Splice Del
 Splice Lev
 Splice Tim
 WebBr Menu
 Webbr Lev.
 Webbr Time
Range Exp.
 RE Source
 Ranges
 Start No.
 Dn Level
 Up Level
 Range Time
 Brake Menu
 Range Dia Menu
 Dia. Menu
 Diamet.Src
 P/Rev Roll
 mm/Pulse
 Min Diam.
 Max Diam.
 Fac. Diam
 DF AutoSet
 New Roll D
 Diameter
 Com Menu (optional)

3.11 Range Expander of D-3100ce-UW

Range expansion divides the torque capabilities of a braking system into multiple ranges. Only ranges required for a desired torque are active at any given time. This feature allows a braking system to run a much wider range of materials and tension settings. Each combination uses the braking system to its maximum potential and efficiency.

With a normal braking system, each brake pad is connected in parallel to a regulated air output. The pads may be divided into groups called ranges using the range expander, which requires a P-3000 RE pneumatic interface. There can be anywhere between 2 and 4 ranges. Each range is driven from a separate valve switch in the P-3000. Using this method, only the ranges required for adequate torque within the linear range of brake functionality are active. The range expander will automatically switch in the number of ranges that are required and raise or reduce pressure on the brake accordingly. This will maintain the same tension across ranges. .

Large web tension variance	Small rolls/light material through large rolls/heavy material on the same machine
Fast stop with high inertia rolls	Large rolls with low tension

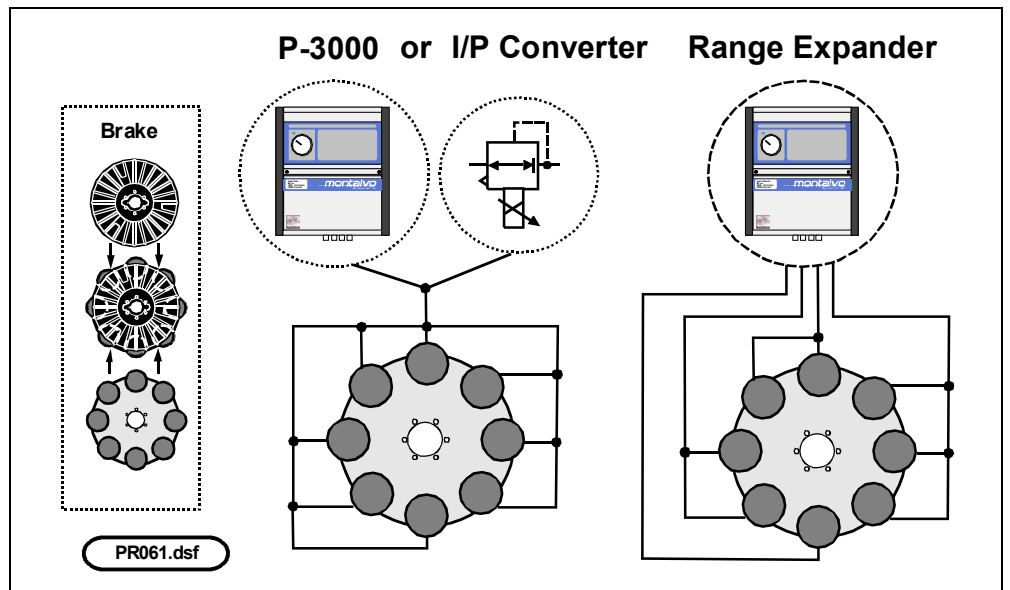

The range expander operates in two modes, output or diameter:

Changing Ranges by Tracking Output Pressure

Output Mode. The range expander will change to a lower range when output pressure regulates below 20% [Dn Level] for more than 20 seconds (range time) or to a higher range when output pressure regulates over 80% [Up Level] for more

- Diagnostic
- Password
- Setup Menu
 - Mode Menu
 - Run Mode
 - Amplifier
 - Regulator Menu
 - Gain Min.
 - Gain Max.
 - Gain Mid.
 - Sys. Gain
 - P Level
 - D Level
 - Gain Src
 - Softs Menu
 - Start Out
 - Softs Lev.
 - Softs Time
 - Hold Level
 - Anti Menu
 - Anti.Src.
 - Anti Max
 - Anti Min
 - Anti Slope
 - Splice Menu
 - Splice Src
 - Splice Del
 - Splice Lev
 - Splice Tim
 - WebBr Menu
 - Webbr Lev.
 - Webbr Time
- Range Exp.**
 - RE Source**
 - Ranges**
 - Start No.**
 - Dn Level**
 - Up Level**
 - Range Time**
 - Brake Menu**
 - Pads R1**
 - Pads R2**
 - Pads R3**
 - Pads R4**
 - Randomize**
- Range Dia Menu**
 - 4->3 Dia**
 - 3->2 Dia**
 - 2->1 Dia**
- Dia. Menu
 - Diamet.Src
 - P/Rev Roll
 - mm/Pulse
 - Min Diam.
 - Max Diam.
 - Fac. Diam
 - DF AutoSet
 - New Roll D
 - Diameter
- Com Menu(optional)

than 20 seconds (range time). During a range shift, the pressure is changed automatically to keep the same torque on the brake.

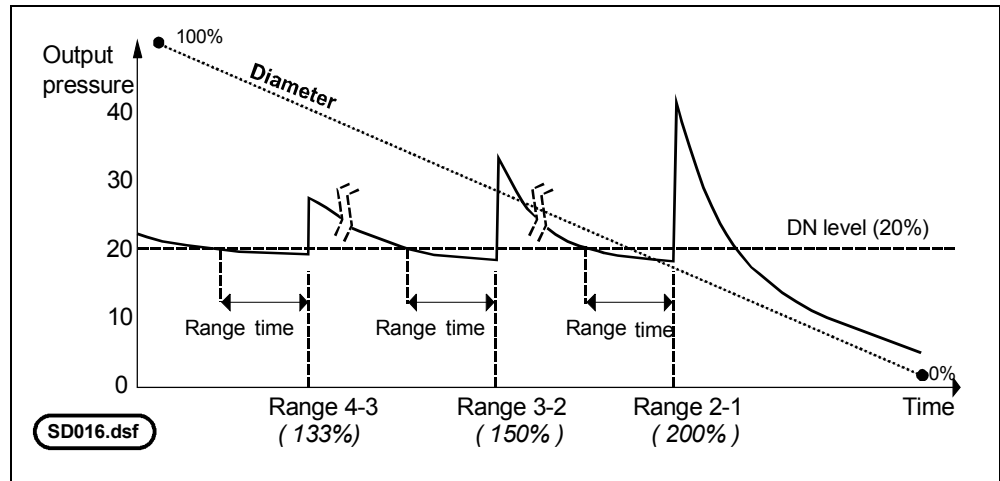

Illustration of diameter, range, and pressure changes during a typical unwind cycle under output pressure control

Changing Ranges by Tracking Diameter

Diameter Mode. The range expander will change to a lower range when the roll diameter is smaller than the switching diameter, or change to a higher range shift-up when roll diameter is greater than switching diameter. The controller automatically calculates the best switching diameters based on brake geometry. During a range shift, the pressure is changed automatically to keep the same torque on the brake.

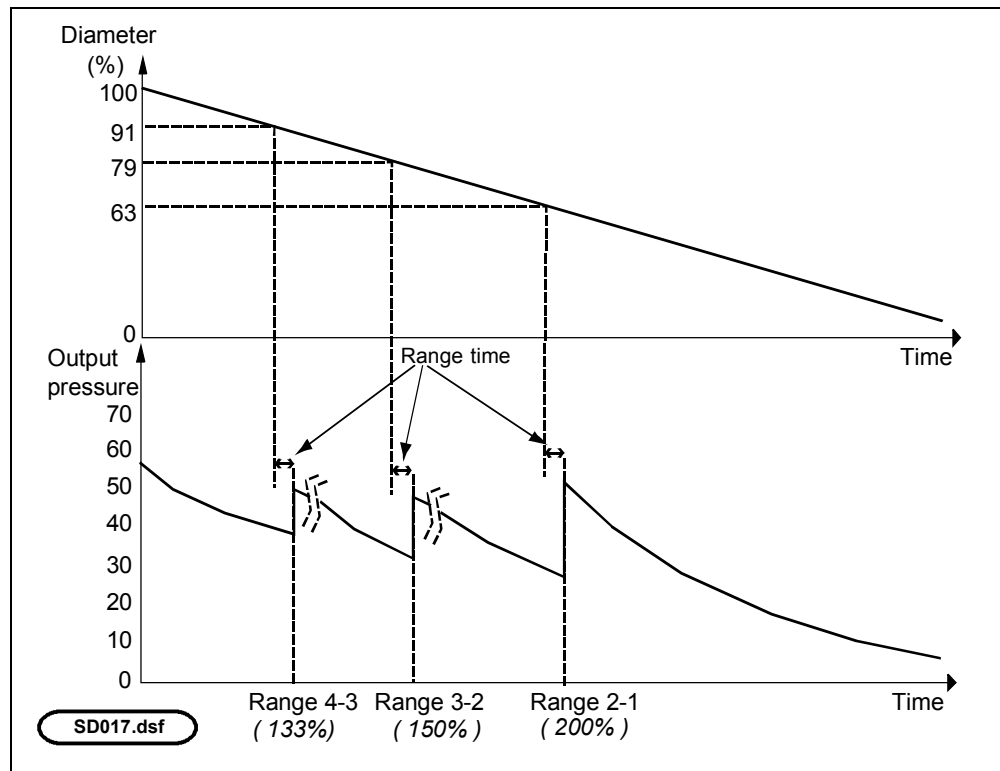
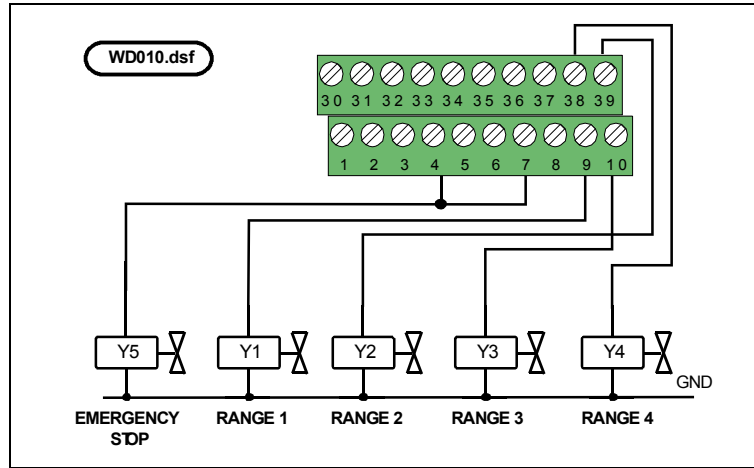

Illustration of diameter, range, and pressure changes during a typical unwind cycle under diameter control

Electrical Wiring

Without Emergency Stop



With Emergency Stop

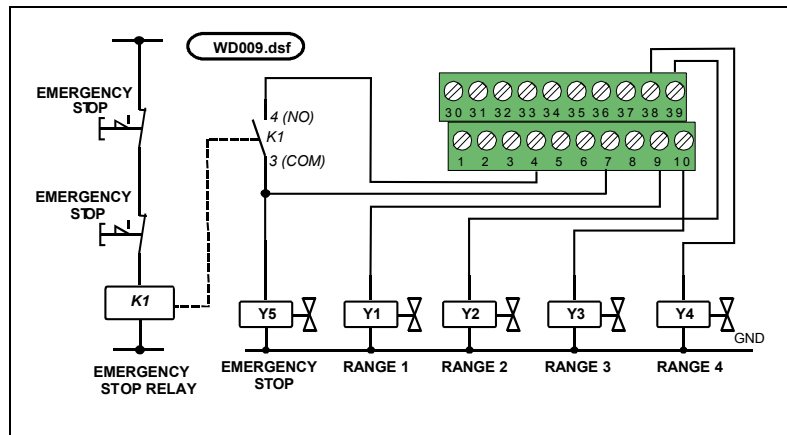

Pneumatic Diagram

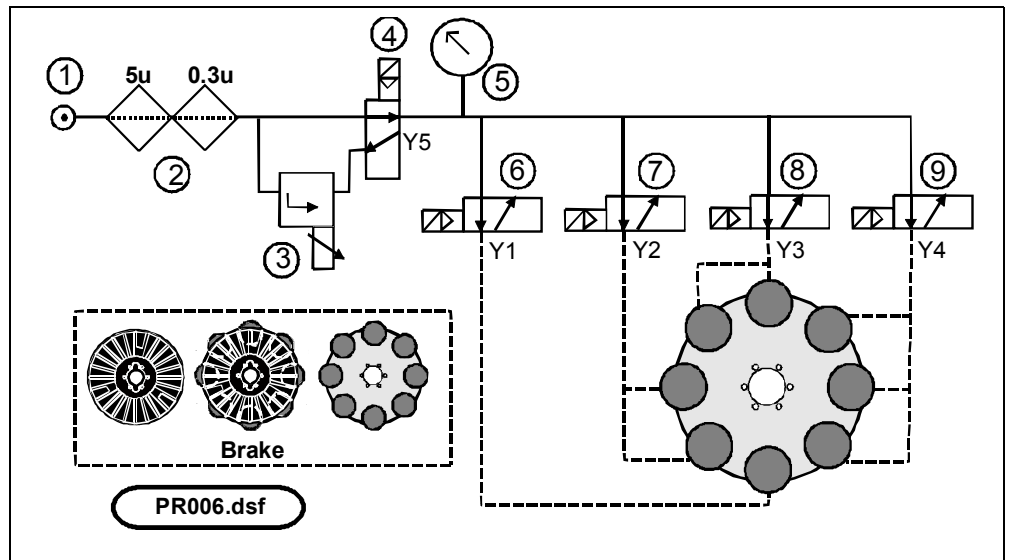

1	Air supply, 6-8 bar
2	Air filter
3	I/P converter, 0-6 Bar
4	Emergency stop valve
5	Manometer
6	Range 1 valve
7	Range 2 valve
8	Range 3 valve
9	Range 4 valve

- Setup Menu
 - Mode Menu
 - Run Mode
 - Amplifier
 - Regulator Menu
 - Gain Min.
 - Gain Max.
 - Gain Mid.
 - Sys. Gain
 - P Level
 - D Level
 - Gain Src
 - Softs Menu
 - Start Out
 - Softs Lev.
 - Softs Time
 - Hold Level
 - Anti Menu
 - Anti.Src.
 - Anti Max
 - Anti Min
 - Anti Slope
 - Splice Menu
 - Splice Src
 - Splice Del
 - Splice Lev
 - Splice Tim
 - WebBr Menu
 - Webbr Lev.
 - Webbr Time
 - Range Exp.**
 - RE Source**
 - Ranges**
 - Start No.**
 - Dn Level**
 - Up Level**
 - Range Time**
 - Brake Menu**
 - Pads R1**
 - Pads R2**
 - Pads R3**
 - Pads R4**
 - Randomize**
 - Range Dia Menu**
 - 4->3 Dia**
 - 3->2 Dia**
 - 2->1 Dia**
 - Dia. Menu
 - Diamet.Src
 - P/Rev Roll
 - mm/Pulse
 - Min Diam.
 - Max Diam.
 - Fac. Diam
 - DF AutoSet
 - New Roll D
 - Diameter
 - Com Menu(optional)

Parameter Setting and Adjustment

To set up parameters in the range expander menu, go to range expansion [**Range Exp .**] under setup menu and do the following:

1. [RE Source] (Range expander source)

Select one of three modes of operation for the range expander:

[NONE]	Range expander not used
[DIA]	Range expander runs under diameter control
[OUTPUT]	Range expander runs under output pressure control

Note: The factory recommends the following setup:

- D-3100ce-UW= [DIA.]
- DTI-3100ce-UW= [OUTPUT] or [DIA.]
- X-3100ce-UW= [OUTPUT] or [DIA.]

Note: All remaining range expansion parameters must be set in **Tension off mode**.

2. [Ranges]

Select the number of ranges in your system: **2, 3 or 4**.

3. [Start No.]

Select the starting range number: **1, 2, 3 or 4**.

This range is used after a range expander reset, which occurs after the following three conditions:

- Power has been applied to the controller.
- Tension has been switched on (new roll).
- Controller has performed a splice operation.

Recommended: choose this value to reflect most frequently used material and roll diameter.

4. [Dn Level] when [RE source = OUTPUT]

If output level is below the [Dn Level] longer than [Range Time], the controller will switch down one range.

5. [Up Level] when [RE source = OUTPUT]

If output level is over the [Up Level] longer than [Range Time], the controller will switch up one range.

Diagnostic
 Password
 Setup Menu
 Mode Menu
 Run Mode
 Amplifier
 Regulator Menu
 Gain Min.
 Gain Max.
 Gain Mid.
 Sys. Gain
 P Level
 D Level
 Gain Src
 Softs Menu
 Start Out
 Softs Lev.
 Softs Time
 Hold Level
 Anti Menu
 Anti.Src.
 Anti Max
 Anti Min
 Anti Slope
 Splice Menu
 Splice Src
 Splice Del
 Splice Lev
 Splice Tim
 WebBr Menu
 Webbr Lev.
 Webbr Time
Range Exp.
 RE Source
 Ranges
 Start No.
 Dn Level
 Up Level
 Range Time
 Brake Menu
 Pads R1
 Pads R2
 Pads R3
 Pads R4
 Randomize
 Range Dia Menu
 4->3 Dia
 3->2 Dia
 2->1 Dia
 Dia. Menu
 Diamet.Src
 P/Rev Roll
 mm/Pulse
 Min Diam.
 Max Diam.
 Fac. Diam
 DF AutoSet
 New Roll D
 Diameter
 Com Menu(optional)

6. [Range Time]

This is the delay time before the controller switches one of the ranges in or out. The following criteria will start the time delay:

- a) If output is under [Dn Level] , [RE source=OUTPUT]
- b) If output is over [Up Level] , [RE source=OUTPUT] .
- c) If a diameter switch-point is reached, [RE source=DIA] .

Note: In all conditions, controller must run in auto mode before switching.

7. Enter [Brake Menu] sub-menu

[Pads 1] **Note:** This is the number of brake pads in each of the possible ranges.
 [Pads 2] You do not need to set values for ranges that are > [Ranges] .
 [Pads 3]
 [Pads 4]

For example: If [Ranges]= 2, only [Pads 1] and [Pads 2] should be set.

- d) [Randomize YES] or [Randomize NO]

For equal wear of brake pads, randomize starting range.

If [Randomize YES] is selected, controller will rotate among the lowest ranges with equal numbers of brake pads. (Range 1 is the lowest range, Range 4 the highest.)

8. [Range Dia Menu] when (Range Diameter Menu)

[4/3 Dia] The best diameter switch points for the controller. The switch points are
 [3/2 Dia] calculated from the information set up in brake menu.
 [2/1 Dia]

Note: This is only a readout parameter.

3.12 Diameter

The diameter function is necessary in the following instances:

- Control of gain
- Reduction of tension (taper) on rewinder
- Control of stop level at anticoast
- Control of range expander in some special versions

The diameter can be calculated in 2 different ways:

[LOCAL]	The processor calculates a diameter from the output. <i>This way will not work in applications requiring a wide web tension range.</i>
[PULSE]	Diameter calculated from two digital input signals (2 proximity switches).
[ANALOG]	Diameter from an external analog input signal.

1. Diameter Calculated From Output [LOCAL]

A function most often used in standard load cell applications. The diameter calculated is approximate, and not useful in applications requiring precise diameters.

2. Diameter Calculated From 2 Proximity Switches [PULSE]

The roll diameter is calculated during running by 2 proximity switches, one that senses roll revolutions (location 1) and the other that senses web speed (locations 2, 3 or 4). At the start-up after roll change, the diameter of the new roll is calculated when the controller has received 2 pulses from the new roll. Pulse diameter calculations are recommended for machines with a wide web tension range; these calculations also improve fast stop function.

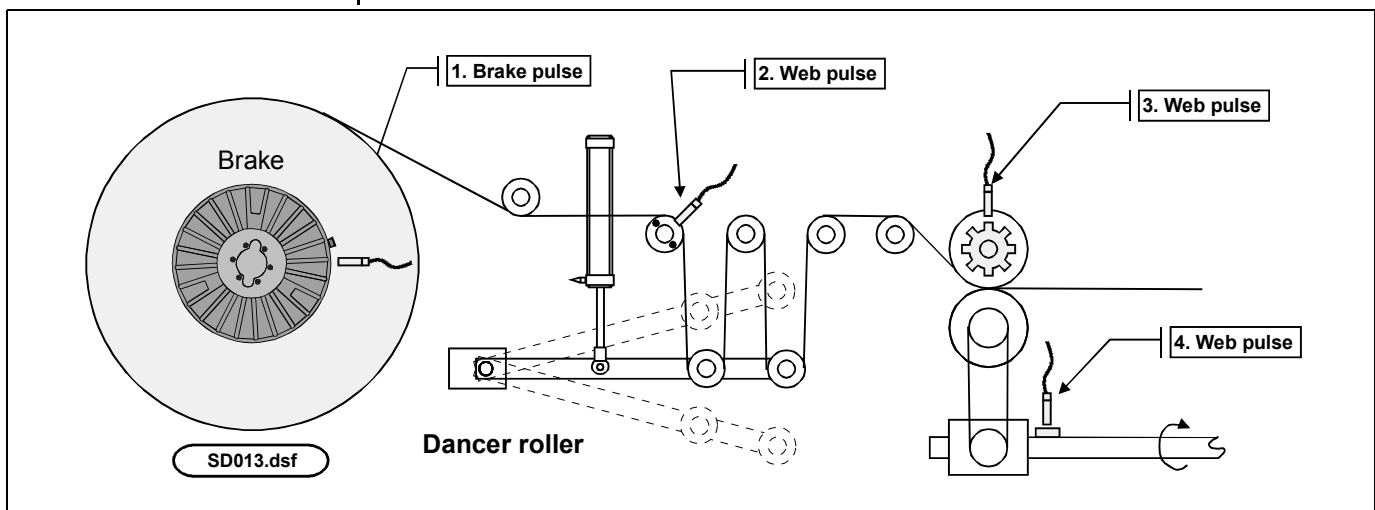

Calculation of roll diameter

Diagnostic
 Password
 Setup Menu
 Mode Menu
 Run Mode
 Amplifier
 Regulator Menu
 Gain Min.
 Gain Max.
 Gain Mid.
 Sys. Gain
 P Level
 D Level
 Gain Src
 Softs Menu
 Start Out
 Softs Lev.
 Softs Time
 Hold Level
 Anti Menu
 Anti.Src.
 Anti Max
 Anti Min
 Anti Slope
 Splice Menu
 Splice Src
 Splice Del
 Splice Lev
 Splice Tim
 WebBr Menu
 Webbr Lev.
 Webbr Time
 Range Exp.
 RE Source
 Ranges
 Start No.
 Dn Level
 Up Level
 Range Time
 Brake Menu
 Range Dia Menu
Dia. Menu
 Diamet.Src
 P/Rev Roll
 mm/Pulse
 Min Diam.
 Max Diam.
 Fac. Diam
 DF AutoSet
 New Roll D
 Diameter
 Com Menu (optional)

a) Brake Pulse (Terminal 35)

A proximity switch that pulses 1 to 4 times per revolution during rotation of the roll is mounted on the unwind. It is best mounted where you can sense a keyway, a screw, or a bored hole in the shaft; other possible sensing locations are the safety chucks and the brake.



Warning: Do not place the proximity switch where it will be overheated by the brake.

Note: Maximum input frequency must not exceed 80Hz.

b) Web Pulse (Terminal 5)

A proximity switch is mounted to sense the web length/pulse. The best location for measuring web speed is location 2 because the speed will not be altered by movement of the dancer roller. Locations 3 and 4 will give inaccurate diameter calculations in the first 5 or 10 revolutions because of the movement of the dancer roller. The recommended web length/pulse is between 10 and 250 mm/pulse. For better resolution, use short distances between pulses.

Note: Maximum input frequency must not exceed 800Hz.

3. Diameter From External Analog Input [ANALOG]

An external analog signal can also be used. The signal must be a 0-10 VDC signal that equals a diameter of 0 to 100%. However, any signal between 2 to 6 VDC or 4 to 9 VDC can still be used because it is connected to a circuit with “zero and span” adjustments, after which it goes to the microprocessor. See diagram below:

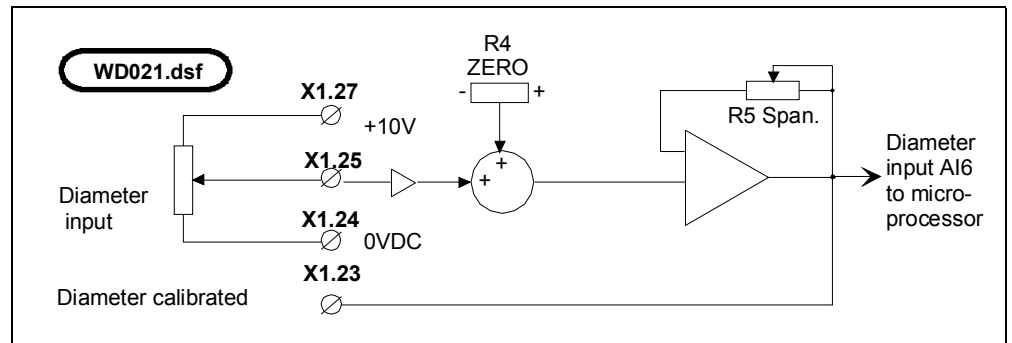

```

Diagnostic
Password
Setup Menu
  Mode Menu
    Run Mode
    Amplifier
  Regulator Menu
    Gain Min.
    Gain Max.
    Gain Mid.
    Sys. Gain
    P Level
    D Level
    Gain Src
  Softs Menu
    Start Out
    Softs Lev.
    Softs Time
    Hold Level
  Anti Menu
    Anti.Src.
    Anti Max
    Anti Min
    Anti Slope
  Splice Menu
    Splice Src
    Splice Del
    Splice Lev
    Splice Tim
  WebBr Menu
    Webbr Lev.
    Webbr Time
  Range Exp.
    RE Source
    Ranges
    Start No.
    Dn Level
    Up Level
    Range Time
    Brake Menu
  Range Dia Menu
Dia. Menu
  Diamet. Src
  P/Rev Roll
  mm/Pulse
  Min Diam.
  Max Diam.
  Fac. Diam
  DF AutoSet
  New Roll D
  Diameter
Com Menu(optional)
    
```

Electrical Wiring

Provided is an example of connecting the analog diameter signal and the 2 proximity switches.

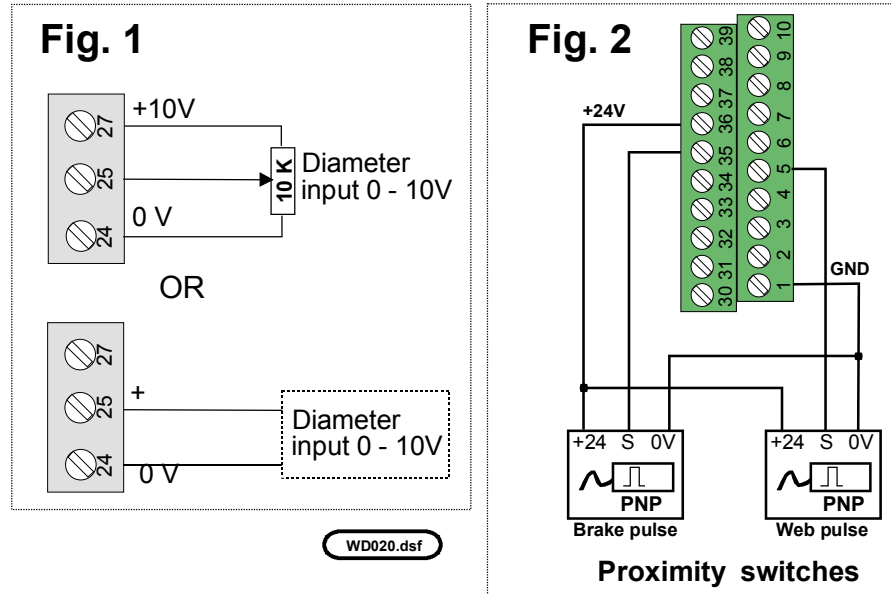

Parameter Setting and Adjustment

To set up parameters in the diameter menu, go to diameter menu in setup menu and do the following:

1. [Diamet Src] (Diameter source)

Select one of three modes for diameter.

[LOCAL]	Processor calculates diameter from output (factory setup)
[PULSE]	Diameter is calculated from 2 proximity switches.
[ANALOG]	Diameter from an analog input signal.

a) If [LOCAL] is source, set up the following parameters:

[Min Diam]	(Minimum diameter). Min. roll size in percentages (0-100%).
[Max Diam]	(Maximum diameter). Max. roll size in percentages (0-100%).

- 1) Install a roll and measure its diameter (0-100%).
- 2) Scroll to parameter Diameter Factor Auto setup [DF Auto set].
- 3) Run machine at low speed until dancer has stabilized for 10 seconds.
- 4) Input actual diameter; press **Enter**. When **Enter** is pressed, factor for the diameter will be calculated.

Diagnostic
Password
Setup Menu
 Mode Menu
 Run Mode
 Amplifier
 Regulator Menu
 Gain Min.
 Gain Max.
 Gain Mid.
 Sys. Gain
 P Level
 D Level
 Gain Src
 Softs Menu
 Start Out
 Softs Lev.
 Softs Time
 Hold Level
 Anti Menu
 Anti.Src.
 Anti Max
 Anti Min
 Anti Slope
 Splice Menu
 Splice Src
 Splice Del
 Splice Lev
 Splice Tim
 WebBr Menu
 Webbr Lev.
 Webbr Time
 Range Exp.
 RE Source
 Ranges
 Start No.
 Dn Level
 Up Level
 Range Time
 Brake Menu
 Range Dia Menu
Dia. Menu
 Diamet.Src
 P/Rev Roll
 mm/Pulse
 Min Diam.
 Max Diam.
 Fac. Diam
 DF AutoSet
 New Roll D
 Diameter
 Com Menu (optional)

b) If [PULSE] is source, set up the following parameters:

[P/rev Roll]	number of pulses per revolution on the roll.
[mm/Pulse]	mm between pulses on the main machine.
[Min Diam]	minimum roll size in mm.
[Max Diam]	maximum roll size in mm.

c) If [ANALOG] is source, set up the following parameters:

[Min Diam]	minimum roll size in % (0-100%)
[Max Diam]	maximum roll size in % (0-100%)

- 1) Scroll to parameter [Diameter] .
- 2) Enter analog value for minimum diameter and adjust on potentiometer R4 until 0% is displayed.

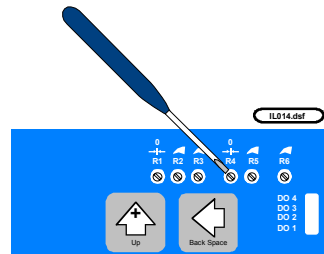

- 3) Enter analog value for maximum diameter and adjust on potentiometer R5 until 100% is displayed.

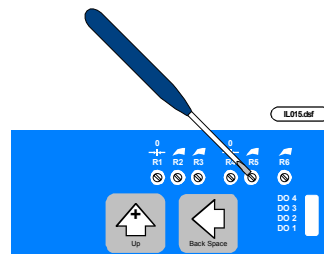

2. [New Roll D] (New Roll Diameter)

New Roll Diameter is the diameter to which, after roll change, the controller is set until the calculation of the correct diameter by running again. New Roll Diameter is automatically set to the maximum diameter when a new maximum diameter is entered. If application does not require maximum diameter, the parameter can be adjusted.

3. [Diameter] (Diameter)

The current calculated diameter based upon previously set parameters.

```

Diagnostic
Password
Setup Menu
  Mode Menu
    Run Mode
    Amplifier
  Regulator Menu
    Gain Min.
    Gain Max.
    Gain Mid.
    Sys. Gain
    P Level
    D Level
    Gain Src
  Softs Menu
    Start Out
    Softs Lev.
    Softs Time
    Hold Level
  Anti Menu
    Anti.Src.
    Anti Max
    Anti Min
    Anti Slope
  Splice Menu
    Splice Src
    Splice Del
    Splice Lev
    Splice Tim
  WebBr Menu
    Webbr Lev.
    Webbr Time
  Range Exp.
    RE Source
    Ranges
    Start No.
    Dn Level
    Up Level
    Range Time
  Brake Menu
  Range Dia Menu
Dia. Menu
  Diamet.Src
  P/Rev Roll
  mm/Pulse
  Min Diam.
  Max Diam.
  Fac. Diam
  DF AutoSet
  New Roll D
  Diameter
Com Menu(optional)
  
```

3.13 Gain Control From Diameter

Gain control from diameter results in more effective regulation in machines with wide web tension areas. Low tension is difficult to control between a large and an empty roll because of high inertia. Gain control insures correct tension regulation with all roll sizes and tension areas. Roll diameter is used to control gain.

Parameter Setting and Adjustment

Note: To make the correct setup and adjustments, connect and adjust diameter before making the following setup:

To set up and adjust:

1. Scroll to the [Regulator Menu]
2. Set the [Gain Src (Source) = DIA.]
3. Run with a roll with minimum diameter and adjust the [P Level] and [D Level] so that the regulation is constant.
4. If [P Level] gets too low, i.e. < 5, then adjust [Sys. Gain] down so that it is possible to run with a [P Level] on 10.
5. Change to a roll between 80 to 100% in diameter and run machine again. Adjust now at the [Gain Max.] level under the [Regulator Menu] so that the regulation is correct at that diameter.
6. The shape of the gain curve between the minimum and maximum values is controlled by the [Gain Mid.] parameter and is adjustable between 1.0 and 3.0. This parameter is the exponent in the equation:

$$\text{Gain} = \text{Diameter}^{\text{[Gain Mid.]}} * \text{[Gain Max.]} + \text{[Gain Min]}$$

Diagnostic
 Password
 Setup Menu
 Mode Menu
 Run Mode
 Amplifier
 Regulator Menu
 Gain Min.
 Gain Max.
 Gain Mid.
 Sys. Gain
 P Level
 D Level
 Gain Src
 Softs Menu
 Start Out
 Softs Lev.
 Softs Time
 Hold Level
 Anti Menu
 Anti.Src.
 Anti Max
 Anti Min
 Anti Slope
 Splice Menu
 Splice Src
 Splice Del
 Splice Lev
 Splice Tim
 WebBr Menu
 Webbr Lev.
 Webbr Time
 Range Exp.
 RE Source
 Ranges
 Start No.
 Dn Level
 Up Level
 Range Time
 Brake Menu
 Range Dia Menu
 Dia. Menu
 Diamet.Src
 P/Rev Roll
 mm/Pulse
 Min Diam.
 Max Diam.
 Fac. Diam
 DF AutoSet
 New Roll D
 Diameter
 Com Menu (optional)

If the gain at large and small roll are adjusted correctly, but the mid-roll gain is either too large or too small:

- a) Run with a roll approximately 33% in diameter.
- b) Increase [Gain Mid.] to reduce the mid-roll gain.
- c) Decrease [Gain Mid.] to raise the mid-roll gain.

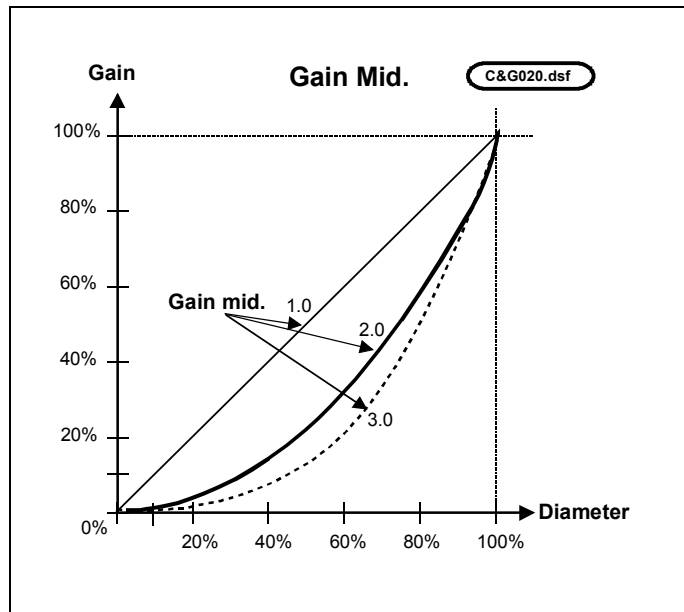

3.14 Operating the Controller Menu

The controller operates in two modes:

- **Scroll Mode**
- **Edit Mode (the cursor blinks)**

And has three types of menu items:

- *submenu*
- *numeric parameter*
- *textual parameter*

Menus are arranged in a hierarchical tree structure. The controller starts in scroll mode. A **submenu** is any menu below the current menu. A **parent menu** is any menu above the current menu.

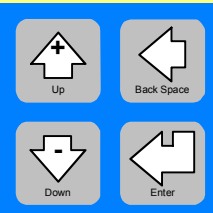

Up ↑: Move to previous menu item.
Down ↓: Move to next menu item.
Back Space ←: Move to parent menu.
Enter ↵: Enter menu if a submenu, or **change** to edit mode if a numeric or textual parameter.

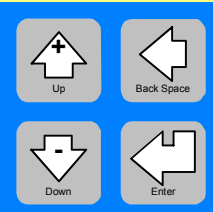

Up ↑: Increase numeric parameter value or move to previous textual parameter value.
Down ↓: Decrease numeric parameter value or move to next textual parameter value.
Back Space ←: Cancel edit, returning to previous value.*
Enter ↵: Store edit and return to scroll mode.

***Note:** Back Space does not apply to "live" edit parameters. In a live edit parameter, the value is automatically stored when a change is made: the previous value cannot be returned to.

Example: in the following instance, the user increases the value of [Softs Time] to 3.0 seconds. With the controller displaying [Diagnostic], the required steps are as follows:

- Press **Down** (↓) until [Setup Menu] appears on the display. Press **Enter** (↵) to enter the submenu.
- Press **Down** (↓) until [Softs Menu] appears on the display. Press **Enter** (↵) to enter the submenu.
- Press **Down** (↓) until [Softs Time] appears. Press **Enter** (↵) to edit the parameter. (The cursor will blink.)
- Press **Up** or **Down** (↑↓) until 3.0 appears on the display.
- Press **Enter** (↵) to store change.

```

↓Diagnostic
↓Password
↵Setup Menu
  ↵Softs Menu
    ↓Start Out
    ↓Softs Lev.
    ↵Softs Time
    [↑↓] ↵
    
```

3.15 Menu Tree Diagnostic and Setup

The diagnostic menu below shows the different analog inputs for operation; the following menu describes setup.

Diagnostic Menu

Main menu	Submenu	Description
DIAGNOSTIC		Main menu
	VERSION	Software version
	RUN MODE	Shows the actual run mode (see run mode menu below).
	DANCER	Analog input no. 6, dancer position: –110% to 110%
	SETPOINT	Analog input no. 1, setpoint: 0% to 110%
	OUTPUT	Analog input no. 8, output: –110% to 110%
	I-LEVEL	Analog input no. 3, integrator: –110% to 110%
	MANUAL	Analog input no. 4, manual level: –110% to 110%
	SPLICE	Analog input no. 5, splice level: –110% to 110%
	SUMMATION	Analog input no. 7, summing input: 0 to 110%
	DIAMETER	Calculated diameter 0 to 100%
	OUTPUT2	Shows the level on the extra analog output
PASSWORD		Password gives access to setup and factory menus. Use password 5 to enter SETUP menu.

Run Mode Menu

[AUTO]	The controller is in auto mode. The controller receives a signal from the position of the dancer roll potentiometer and automatically regulates the pressure to the brake until the dancer roll is in center position.
[MANUAL]	The controller is in manual mode. Constant output level is set with manual setpoint.
[SOFTST]	The softstart signal on terminal 34 goes low (0 VDC). The output changes from [Hold Level] to [Soft Level], then the controller goes in to auto mode.
[ANTIC.]	Anticoast signal on terminal 6 goes high (+24 VDC) and controller applies the anticoast level to the output level and continues to regulate.
[STWAIT]	1. Anticoast terminal 6 is high (+24 VDC) and controller waits on [Soft Time] to run out. 2. Softstart signal is high (+24 VDC) and controller waits on [Soft Time] to run out.
[HOLD]	When [Soft Time] has run out and the machine is stopped, output is set to [Hold Level].
[TENOFF]	Tension Off is activated and output level is set to zero.
[SPLICE]	Splice signal terminal 2 is activated (+24 VDC). The controller is performing a splice.

3.16 Menu Tree

A complete menu tree for the D-3100ce-UW appears below. Please note that not all menus appear in the margins all the time. Menus either irrelevant to the mode or without correct passwords will not appear in this section.

```
Diagnostic
  Version
  Run Mode
  Dancer
  Setpoint
  Output
  I-Level
  Manual
  Splice
  Summation
  Diameter
  Output2
Password
Setup Menu
  Mode Menu
    Run Mode
    Amplifier
  Regulator Menu
    Gain Min.
    Gain Max.
    Gain Mid.
    Sys. Gain
    P Level
    D Level
    Gain Src
  Softs Menu
    Start Out
    Softs Lev.
    Softs Time
    Hold Level
  Anti Menu
    Anti.Src.
    Anti Max
    Anti Min
    Anti Slope
  Splce Menu
    Splice Src
    Splice Del
    Splice Lev
    Splice Tim
  WebBr Menu
    Webbr Lev.
    Webbr Time
  Range Exp.
  RE Source
  Ranges
  Start No.
  Dn Level
  Up Level
  Range Time
  Brake Menu
    Pads R1
    Pads R2
    Pads R3
    Pads R4
    Randomize
  Range Dia Menu
    4->3 Dia
    3->2 Dia
    2->1 Dia
  Dia. Menu
    Diamet.Src
    P/Rev Roll
    mm/Pulse
    Min Diam.
    Max Diam.
    Fac. Diam
    DF AutoSet
    New Roll D
    Diameter
  Com Menu(optional)
```

3.17 Setup Menu

Main menu	Submenu 1	Submenu 2	Description	Enter
SETUP MENU			Main menu	No
	MODE MENU			No
		RUN MODE	Dancer unwind, D-UW (see run mode menu below)	R
		AMPLIFIER	1 or x10 preamplifier	E
	REGULATOR MENU			
		GAIN MIN.	System gain 0 to 50	
		GAIN MAX.	System ratio 0 to 500	
		GAIN MID.	0 to 3.0	
		SYS. GAIN	0 to 63	
		P-LEVEL	Proportional level 0 to 63	
		D-LEVEL	Derivative level 0 to 63	
		GAIN SRC		
	SOFTS MENU		Submenu for softstart: enter to change parameters.	No
	ANTI MENU		Submenu for anticoast: enter to change parameters.	No
	SPLCE MENU		Submenu for splice: enter to change parameters.	No
	WEBBR MENU		Submenu for web break: enter to change parameters.	No
	RANGE EXP.		Submenu for range expander: enter this menu to change parameters.	No
	DIAM.MENU		Submenu for calculation of diameter: enter to change parameters.	No
	OUTPUT2 MENU		Submenu for extra analog output Output2 . Enter this menu to change parameters.	No
	COM. MENU		Parameters used with optional communications packages, RS232 and Fieldbus.	No

3.18 Hardware Adjustment and LEDs

R1 Zero Range	Adjusts position of dancer until display is zero (zero adjustment) (see Section 4.1, p. 67).
R2 Calibration Range	Adjusts dancer maximum position.
R3 Calibration Range	Not used with dancer applications.
R4 Diameter Zero Range	Adjust until 0 is displayed in DIAMETER message (see Section 3.13, p. 60).
R5 Diameter Calibration Range	Adjust until actual diameter is shown in the DIAMETER message (refer to diameter calibration in Section 3.13).
R6 Summation Input Calibration	Not used with D-3100ce-UW.

Potentiometers

R1 = Zero Calibration (Dancer Input)
R2 = Range Calibration 1(Dancer Input)

R3 = not used for this controller.
R4 = not used for this controller.
R5 = not used for this controller.
R6 = not used for this controller.

DO 4	■	
DO 3	■	
DO 2	■	
DO 1	■	
DI 8	■	<p>Digital Input</p> <p>DI8 = Anticoast Terminal 6 DI5 = Softstart Terminal 34 DI3 = Tension off Terminal 32 DI2 = Splice Terminal 2 DI1 = Manual Terminal 31</p>
DI 7	■	
DI 6	■	
DI 5	■	
DI 4	■	
DI 3	■	
DI 2	■	
DI 1	■	

4 Calibration

4.1 Dancer Calibration

1. **Check** for correct installation of dancer potentiometer.
2. **Place** dancer roller in center position, loosen potentiometer coupling, and turn potentiometer shaft until it is approximately in center position (5kΩ between black and white wire). Tighten the coupling again.
3. **Apply** power to the controller and let it warm up for at least 10 minutes. Scroll to the dancer parameter in [**DIAGNOSTIC**] .
4. **Place** the dancer roller in center position and adjust potentiometer R1 until the digital display shows [**DANCER 0%**] under the [**DIAGNOSTIC**] menu.

Note: R1 and R2 are 25-turn potentiometers, so many rotations may be required.

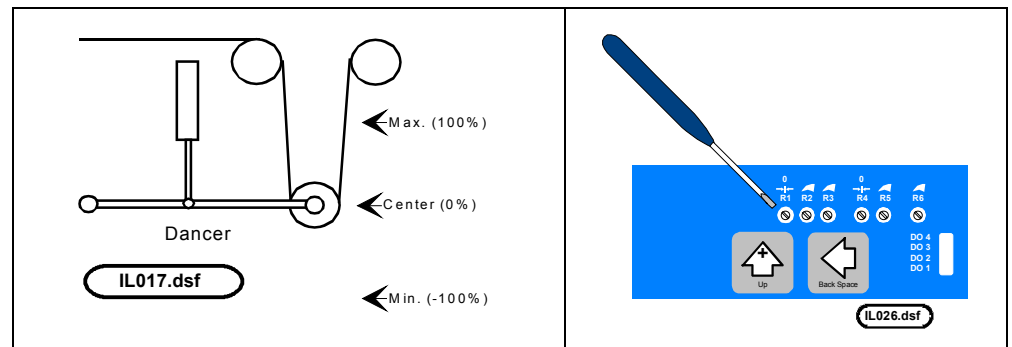

5. **Place** dancer roller in maximum position. If a negative value is displayed, switch the red and black wires coming from the potentiometer, and repeat step 4. Adjust potentiometer R2 until [**DANCER 100%**] appears. If the value is below 100%, turn R2 clockwise; if above, turn counterclockwise.

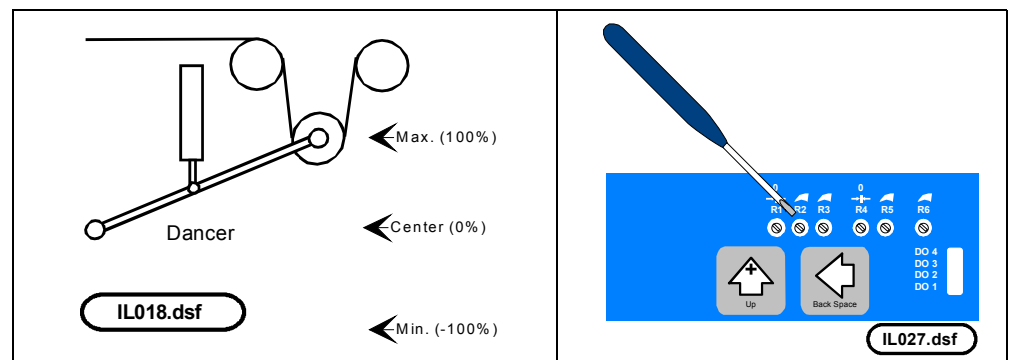

6. **Move** the dancer to the minimum position. The display should show -100%.
 - If the value is *under* -100%, **move** the center position toward *minimum* position.
 - If the value is *over* -100%, **move** the center position toward *maximum* position.
 - To **readjust** center position, **return** to step 4.

- Diagnostic
- Password
- Setup Menu
 - Mode Menu
 - Run Mode
 - Amplifier
 - Regulator Menu
 - Gain Min.**
 - Gain Max.**
 - Gain Mid.
 - Sys. Gain
 - P Level**
 - D Level**
 - Gain Src
 - Softs Menu**
 - Start Out**
 - Softs Lev.**
 - Softs Time**
 - Hold Level**
 - Anti Menu
 - Anti.Src.
 - Anti Max
 - Anti Min
 - Anti Slope
 - Splice Menu
 - Splice Src
 - Splice Del
 - Splice Lev
 - Splice Tim
 - WebBr Menu
 - Webbr Lev.
 - Webbr Time
 - Range Exp.
 - RE Source
 - Ranges
 - Start No.
 - Dn Level
 - Up Level
 - Range Time
 - Brake Menu
 - Range Dia Menu
 - Dia. Menu
 - Diamet.Src
 - P/Rev Roll
 - mm/Pulse
 - Min Diam.
 - Max Diam.
 - Fac. Diam
 - DF AutoSet
 - New Roll D
 - Diameter
 - Com Menu(optional)

4.2 Regulator Menu

Gain Min. This parameter adjusts the speed of the regulator's response to errors on the minimum roll diameter. The parameter can be adjusted in a range of 0 to 100. The higher the value, the faster the reaction to errors. **Not recommended:** parameters lower than 5.

Gain Max. This parameter adjusts the speed of regulator's response to errors on the maximum roll diameter. The parameter can be adjusted in a range of 0 to 500. The higher the value, the faster the reaction to errors. **Not recommended:** parameters lower than 15.

Gain Mid. This parameter adjusts the speed of regulator's response to errors on the middle roll diameter. The parameter can be adjusted in a range of 1.0 to 3.0. The lower the value, the faster the reaction to errors.

Sys.Gain. This parameter is the system gain for the regulator. The parameter can be adjusted in the range of 0 to 63 steps. The higher the value, the faster the reaction to errors. **Not recommended:** parameters lower than 5.

P-level. Proportional gain level of the PID regulator. The parameter can be adjusted in a range of 0 to 63 steps. The higher the value, the bigger the P- level in the PID regulator.

D-level. Derivative gain level of the PID regulator. The parameter can be adjusted in a range of 0 to 63 steps. The higher the value, the bigger the D -level in the PID regulator.

Gain Src. The source for the gain is selected with this parameter. Output or diameter can be selected.

Diagnostic
Password
Setup Menu
 Mode Menu
 Run Mode
 Amplifier
 Regulator Menu
 Gain Min.
 Gain Max.
 Gain Mid.
 Sys. Gain
 P Level
 D Level
 Gain Src
 Softs Menu
 Start Out
 Softs Lev.
 Softs Time
 Hold Level
 Anti Menu
 Anti.Src.
 Anti Max
 Anti Min
 Anti Slope
 Splice Menu
 Splice Src
 Splice Del
 Splice Lev
 Splice Tim
 WebBr Menu
 Webbr Lev.
 Webbr Time
 Range Exp.
 RE Source
 Ranges
 Start No.
 Dn Level
 Up Level
 Range Time
 Brake Menu
 Range Dia Menu
 Dia. Menu
 Diamet.Src
 P/Rev Roll
 mm/Pulse
 Min Diam.
 Max Diam.
 Fac. Diam
 DF AutoSet
 New Roll D
 Diameter
 Com Menu (optional)

4.3 Tuning

1. Adjust dancer as described in Section 4.1.
2. If used, set up range expander before running.
3. If used, set up diameter at the diameter menu described in Section 3.13.
4. If using gain controlled from diameter, follow setup and tuning described in Section 3.13, and skip to step 9 in this section; if not, continue at step 5.
5. Set up **P-Level** and **D-Level**, depending on the number of windings of the web on the dancer roller.

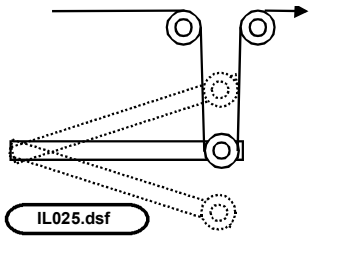
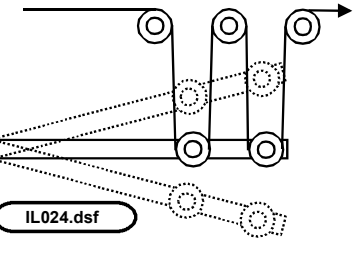
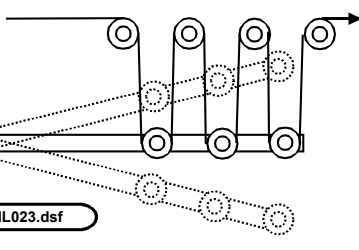
1 wrap:	P-Level = 20 D-Level = 20	
2 wrap:	P-Level = 40 D-Level = 40	
3 wrap:	P-Level = 60 D-Level = 60	

6. Tune with machine running at low speed. Place a small roll in the unwind stand, and adjust [**Gain Min.**] until dancer is stable but still responsive to errors.
7. Place a large roll in unwind stand and adjust [**Gain Max.**] until dancer is stable but still responsive to errors.
8. Scroll to [**Softs Menu**] and adjust the start out, softstart level and softstart time to fit machine acceleration and speed.
9. If anticoast is used, scroll to [**Anti Menu**] and adjust level to fit machine deceleration time.
10. Set up and adjust web break or splice if either is used.

4.4 Customer Parameter Settings

*Visible if and only if diameter source=PULSE. **Visible if and only if diameter source = LOCAL.

Parameter Name:		Parameter Value:	Factory Setting:	Min.	Max.	UNIT
Mode Menu	Mode		D-UNW			
	Amplifier		X1	X1	X10	
Regulator Menu	Gain Min.		5	0	50	
	Gain Max.		50	0	500	
	Gain Mid.		1	0	3	
	Sys. Gain		10	0	63	
	P-Level		20	0	63	
	D-Level		20	0	63	
	Gain Src		OUTPUT			
Softs Menu	Start Out		50	1	100	%
	Softs Lev.		90	0	200	%
	Softs Time		5.0	0.1	99.9	S
	Hold Level		150	0	200	%
Anti Menu	Anti. Src.		OUTPUT			
	Anti max		50	0	500	%
	Anti min		2.0	0.0	20.0	%
	Anti Slope		2.7	0.0	3.0	%
Splice Menu	Splice Src		NONE			
	Splice Del		0.2	0.0	1.0	S
	Splice Lev		50	0	200	%
	Splice Tim		1.0	0.5	5.0	S
WebBr Menu	Webbr Lev.		-95	-95	25	%
	Webbr Time		2.0	1.0	5.0	S
Range Exp.	RE Source		NONE			
	Ranges		1	1	4	
	Start No.		1	1	4	
	Dn Level		20	0	100	%
	Up Level		80	0	100	%
	Range Time		20	1	60	S
	Brake Menu	Pads R1	1	1	10	
		Pads R2	1	1	10	
		Pads R3	1	1	10	
		Pads R4	1	1	10	
		Randomize	YES			
	Range Dia Menu	4->3 Dia	83	0	100	%
		3->2 Dia	56	0	100	%
		2->1 Dia	28	0	100	%
Dia. Menu	Diamet.Src		LOCAL			
	*P/Rev Roll		1	1	900	pulse
	*mm/Pulse		50	1	900	mm
	M in Diam.		10	0	500	
	Max Diam.		100	0	2250	
	**Fac. Diam		200	0	100	%
	**DF Autoset					
	New Roll D		100	0	2250	
	Diameter					%
Com Menu (opt.)						

5 Operation

Output Meter

Displays the regulated output as 0 to 100%. For best controller performance, output should be as high as possible at maximum roll size. With Montalvo brakes, activate or de-activate friction pads to adjust torque capacity.

Mode Switch - Auto / Manual

Selects either the AUTOMATIC (closed loop) or MANUAL (open loop) mode of operation.

Tension Switch

Turns on the regulator output.

Low/High Scale Switch (optional)

Selects calibration range and meter scale in use.

Manual Potentiometer

Sets the output of the controller when in manual mode. Because no automatic regulation is done in manual, the operator must make constant adjustments to maintain the correct dancer position. Additionally, there is no regulation of the range expander.

Auto/Manual Switching

When going from manual to auto, the controller starts at the manual output, then regulates to the output required for automatic control. When switching from AUTO to MANUAL, the controller immediately changes from the auto to the manual set value, which may cause large changes in the position of the dancer. To avoid these changes, note the output while running in automatic. Set the MANUAL potentiometer to the approximate percentage of the auto output to maximum output. For example, if the auto output is 50% of the maximum, set the manual output potentiometer to 50%.

Softstart

When the controller receives a signal for machine stop after the soft start delay time, it switches into **softstart** mode. When the machine is started, the controller automatically switches into the auto mode. **Softstart** prevents needing to start the machine at maximum output in the event the web has slackened after stopping.

Splice Level Potentiometer (optional)

Sets the new roll starting output after splice.

Power Diode

A green LED on the front of the cabinet indicates that the power is on.

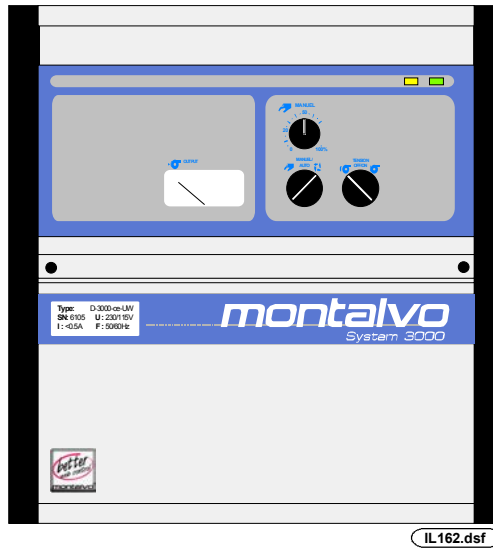

6 Troubleshooting

D-3100ce-UW Block Diagram

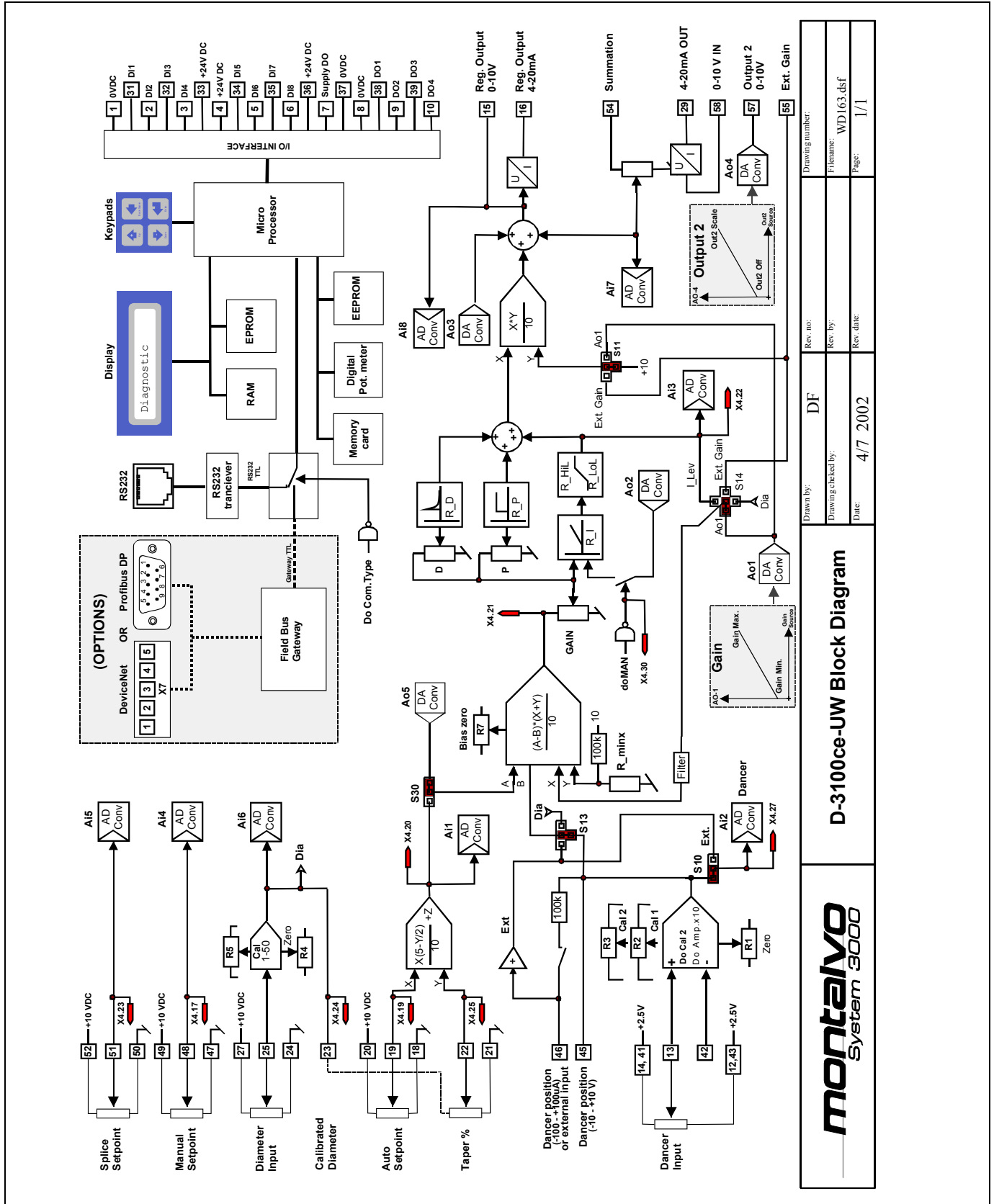

Rev. no:	DF
Rev. by:	
Rev. date:	4/7 2002
File name:	WD163.dsf
Page:	1/1

D-3100ce-UW Block Diagram



Symptom	Cause	Check for
Dancer unstable both in AUTO and MANUAL modes...	<i>Mechanical problem</i>	Bad roll, bad bearings, bent shafts, worn gears, missing teeth, loose chains or belts, line speed variations, brake, clutch or drive problem.
	<i>Pneumatic problem</i>	Fluctuating air input, air leaks, water or oil in air lines.
Dancer and output stable in MANUAL, but unstable in AUTO...	<i>Tuning problem</i>	Check regulator tuning. See Section 4.3, "Tuning," p. 69.
	<i>Regulator problem</i>	Check terminal points - if faulty, consult factory or replace circuit board.
	<i>Converter problem</i>	If signal voltage OK, replace converter.
Dancer does not regulate to center position...	<i>Adjustment problem</i>	See Section 4.1, "Dancer Calibration," p. 67.
Dancer too low both in AUTO and MANUAL modes...	<i>Pneumatic problem</i>	Check input air pressure and for air leaks. I/P converter may be defective.
	<i>Regulator problem</i>	Check terminal points - if faulty, consult factory or replace circuit board.
	<i>Brake/drive problem</i>	Brake/clutch too small, not enough pads activated, motor too small, drive current limit set too low.
Unwind dancer position increases at small roll diameters both in AUTO and MANUAL modes...	<i>Mechanical problem</i>	Bearings in unwind defective, too much friction.
	<i>Pneumatic problem</i>	I/P converter may be defective.
	<i>Regulator problem</i>	Check terminal points, replace regulator if defective.
	<i>Brake problem</i>	Brake too large, too many pads activated.

If use of the controller is no longer required, dispose of it according to the regulations in force at the time.

For service, please contact:

The Montalvo Corporation
 50 Hutcherson Drive
 Gorham, ME 04038 USA
 Tel. (207) 856-2501
 Fax. (207) 856-2509

Danarota Technic A/S
 Gl. Skartved 5 DK-6091 Bjert, Denmark
 Tel. +45 75 57 27 11
 Fax. +45 75 57 29 97

E-mail: info@montalvo.com
 Web site: www.montalvo.com

montalvo
Better Web Control

The Montalvo Corporation • 50 Hutcherson Drive, Gorham, Maine 04038 USA • Email: info@montalvo.com • www.montalvo.com
Tel: (207) 856-2501 • Fax: (207)856-2509 • Toll Free Tel: 1-800-226-8710 • Toll Free Fax: 1-800-644-5097
Technical details subject to change without notice. Printed in U.S.A. X-3100ce-UW © 2001 MONTALVO