



Saves four different material settings

Precise digital ultrasonic measurement

Intelligent tension controller built into sensor

Programmable by operator panel or PC software

Available with Windows PC software for setup and diagnostics

Sensor offers infrared data communication to interface with PC or PDA



System 3000™

U-3500ce Ultrasonic Tension Controller

The Montalvo ultrasonic control system offers cost-effective solutions for non-contact, open-loop tension control applications. The MUS-1ce sensor together with the compact U-3500ce control panel provides a wide range of control configurations for unwind applications (e.g. slitter/rewinders, coaters, laminators). Based on proven ultrasonic technology and the latest in embedded microcontroller technology, the U-3500ce system from Montalvo brings advanced closed-loop system features including softstart, anticoast and inertia compensation, to the open-loop market.

Typical Application

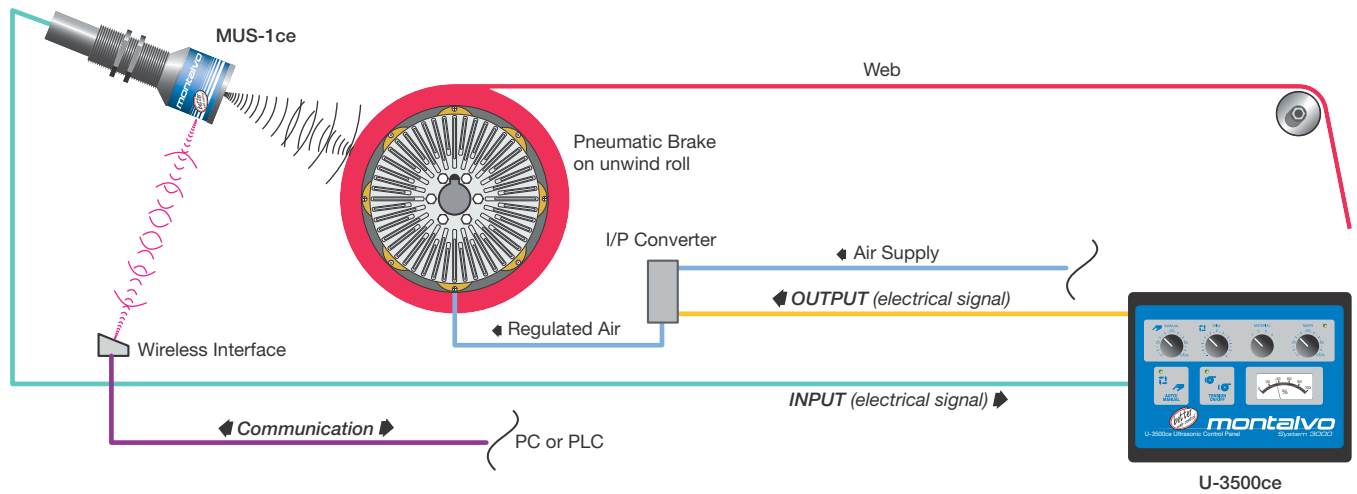

Specifications

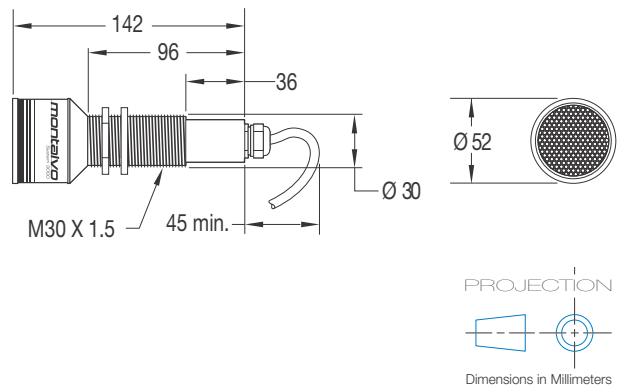
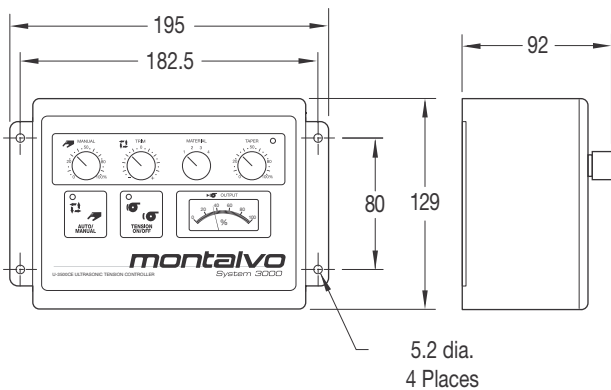

Electrical (U-3500ce)

Supply	115 or 230 VAC \pm 10% 48 to 62 Hz
Optional Supply	24V nominal
Installation Category	II (IEC 664)
Test voltage	3.75 kV
Maximum Power Consumption	3.2 VA
Maximum Fuse Input	10 A
Noise Immunity	EN 50082-2 industrial
Noise Emission	EN 50081-1

Other (U-3500ce)

Temperature Range (operating)	0 to 50°C
Temperature Range (storage)	-10 to 80°C
Pollution Degree	2
Material Fire Classification	94 V0
Degree of Protection	IP54
Standards	Designed to meet UL 508 and EN 60204
Weight (approx.)	1.3 kg
Size (WxDxH)	52mm x 142mm x 52mm

Electrical (MUS-1ce)

Supply	24 VDC nominal (15-30 VDC @ 150 mA)
Maximum Power Consumption	2.5 VA
Noise Immunity	EN50082-2 industrial
Noise Emission	EN 50081-1
Regulator Outputs	4-20 mA RL = 0 - < 500 Ω
Digital Input Voltage	15-30 VDC RI = 10 k Ω
Digital Output Voltage	24 VDC \pm 15% I _{max} for a digital output - 50 mA
Analog Input Voltage	0-10VDC RI = 20 k Ω

Communication (MUS-1ce)

Wireless Interface	IrDA
Type	RS-232

Other (MUS-1ce)

Detection Range	130 to 1500mm
Blind Range	0 to 127mm
Temperature Range (operating)	0 to 50°C
Temperature Range (storage)	-10 to 80°C
Material Fire Classification	94 V0
Degree of Protection	IP54
Weight (4m cable)	0.9 kg
Size (WxDxH)	195mm x 92mm x 129mm