

P-3000-HD

Automatic Range Expander

**Montalvo P-3000-HD Automatic Range Expander**

The Montalvo P-3000HD Automatic Range Expander can allow the widest range of roll sizes and tensions to run properly on virtually any unwind application. Combined with a properly sized Montalvo multi-range brake and our Z4 (or any 3xxx Series X, D or DTI) unwind load cell or dancer tension controllers, the P-3000-HD always keeps the brake in the proper operating range for precise tension control. The system allows for controlled starts and stops, eliminates tension-related web breaks, minimizes downtime, maximizes production and is especially effective on rapid deceleration of dancer controlled sheeters.

Features & Benefits

- ▶ **Emergency Stop Valve** - automatically switches from regulated to line pressure during stops or power failure
- ▶ **Ideal for Large Rolls of Thin Material** - eliminates difficult matching of torque, tension, and stop requirements
- ▶ **Automatic or Manual Version** - automated system or manual control of cylinders on multiple range brakes
- ▶ **Maximum Application Compatibility** - whether load cell or dancer controlled
- ▶ **Analog Readout Gauge** - for easy, convenient pressure monitoring
- ▶ **Complete Pneumatic System**
 - MAF-3 air filter
 - MPC-4 I/P converter
 - pressure gauge
 - valves or switches
 - quick disconnect terminals

Montalvo

P-3000-HD

Automatic Range Expander

How it works

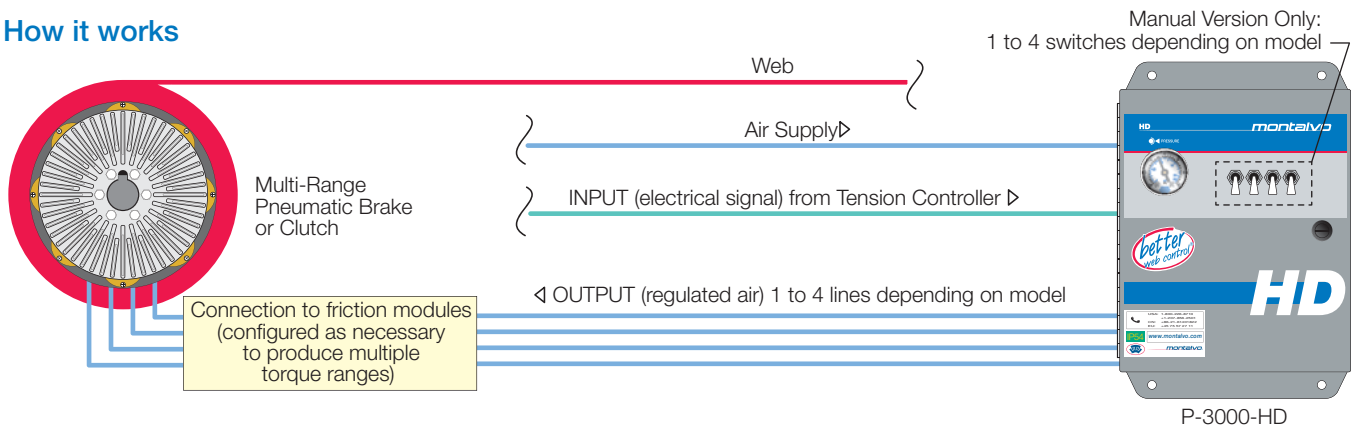

Dimensions

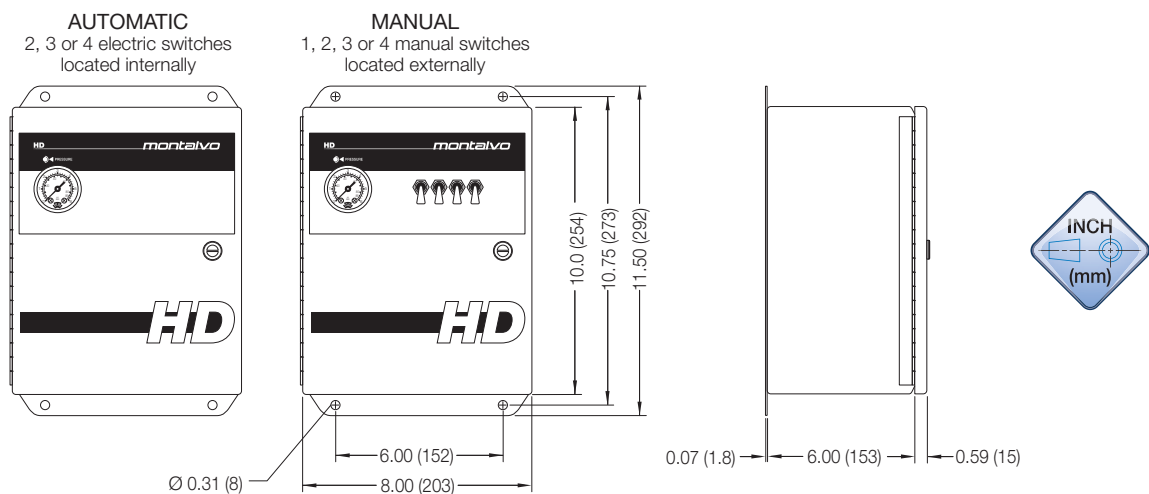

Specifications

Manual Model

P-3000-HD-DA1	1 Switch
P-3000-HD-DA2	2 Switches
P-3000-HD-DA3	3 Switches
P-3000-HD-DA4	4 Switches

Automatic Model

P-3000-HD-RE2	2 Range Valves & Emergency Stop Valve
P-3000-HD-RE3	3 Range Valves & Emergency Stop Valve
P-3000-HD-RE4	4 Range Valves & Emergency Stop Valve

Electrical

MPC-4 I/P Converter (PN 11000392) Supply.....	4-20mA
Solenoid Valve Supply (Automatic Model only)	24VDC
Solenoid Valve Power Consumption (Automatic Model only)(per valve)	0.6W
Standards.....	Designed to meet UL 508 and EN 60204

Pneumatics

Pneumatic Inlet Pressure	80-150 psi
Pneumatic Tube/Fitting Size.....	Ø1/4" (6mm optional)
Pneumatic Outlet/Fitting Size.....	Ø1/4" (6mm optional)
Filtration.....	.5 micron
I/P Converter Flow.....	11 SCFM
I/P Converter Pressure.....	0-75 psi
I/P Converter Accuracy.....	0.01
Emergency Stop Valve Flow (P-3000-HD-RE).....	11 SCFM
Range Expander Valves Flow (P-3000-HD-RE)	3.6 SCFM
Manual Range Valves Flow (P-3000-HD-RE).....	5.4 SCFM

Other

Material Fire Classification.....	94V0
-----------------------------------	------

207-856-2501 / 800-226-8710
 +86-21-52188010
 +45 75 57 27 11
 +49 (0)511 760 691 41

The Montalvo Corporation

EST. 1947

montalvo

Better Web Control®

50 Hutcherson Drive, Gorham, Maine 04038 USA

Fax: 1-800-644-5097 / 207-856-2509

1-800-226-8710 / info@montalvo.com / www.montalvo.com

Technical details subject to change without notice. P-3000-HD-US-02 © Montalvo