

Montalvo

**RU**

**Rotary Union**

**Model:**  
**Kit (HPS Clutches)**

- *Monoflow design*
- *Radial housing connection*
- *Balanced mechanical seal*
- *Oiler for re-lubrication*
- *Low torque*



The RU Rotary Union is a mechanical rotating device that allows the transfer of air to and from rotating equipment. It is recommended for use with our HPS clutch (which requires a constant air flow during rotation) operating at speeds of up to **3500 RPM** and at a maximum air pressure of **75 psi**. The small size is ideal for use in applications with limited space. The RU housing is aluminum and features a carbon graphite hardened tool steel seal.

**Dimensions**

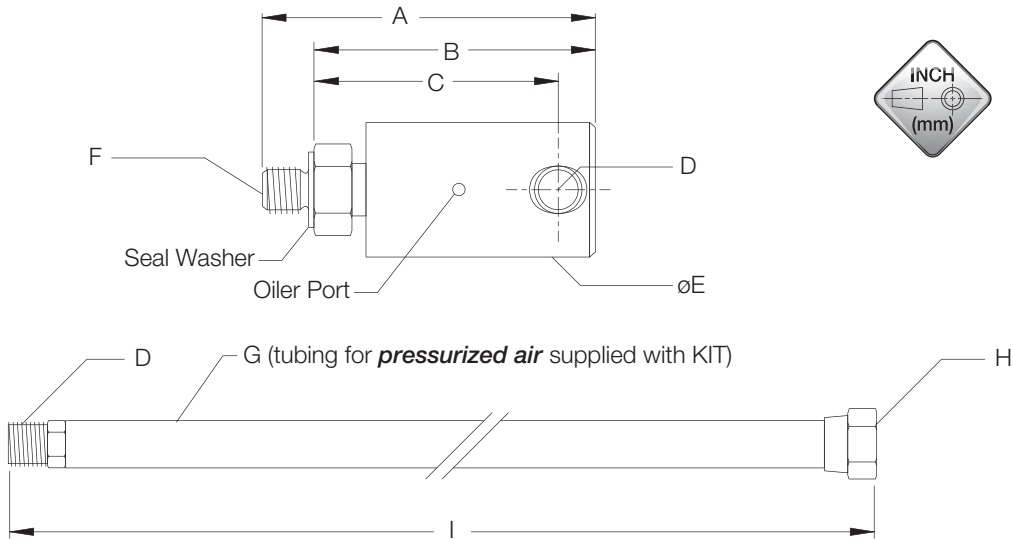

Item	A	B	C	D	E	F	G (I.D.)	H	I
RU-Kit	2.81 (71)	2.31 (58)	2.00 (51)	1/8" NPT	1.13 (29)	3/8"-24 UNF	0.25 (6)	1/4" NPT	18 (457)

BETTERTHANSATAAD



## Specifications

ITEM		RU-Kit (HPS Clutches)
Part Number (kit*)		10000515
Max. Working Air Pressure	psi (bar)	150 (10)
Max. Air Pressure using Montalvo Clutches**	psi (bar)	75 (5.7)
Operating Temperature Range	°F / °C	38-250 (3-121)
Maximum Speed	RPM	3500
Shaft		Steel
Housing		Aluminum
Tap Size		3/8"-24 UNF
Tubing Inside Diameter	in (mm)	0.25 (6)
Tubing Length (approx.)	in (mm)	18 (457)

\* The kit consists of the RU rotary union and a length of tubing with fittings.

\*\* Montalvo Brakes and Clutches operate at a maximum of 75 psi (5.7 bar).

## Installation and Operation Guidelines

### PREPARATION

- Clean end of shaft thoroughly.
- Secure the union by its housing in a vice.
- Be careful not to damage the housing!**

### INSTALLATION

- Attach flexible hose provided or use appropriate customer supplied hose.
- Seal connections with Teflon tape or other sealant.
- Do not use rigid piping!**
- Attach the rotary union to the clutch using Teflon tape, sealant or gasket.
- Arrange and connect hoses without strains, torsional stress or sharp bends.

### BEFORE OPERATION

- Check for leaking connections.





### MAINTENANCE

- The RU has an oiler port. Recommended 3-5 drops high quality motor oil per month.

### REFERENCE

- For use with a Montalvo HPS clutch, see HPS clutch installation instructions.

### Installation Hotlines

	207-856-2501 / 800-226-8710
	+86-21-52188010
	+45 75 57 27 11
	+49 (0)511 760 691 41

