

Dual V

Friction Module

**Montalvo Dual V Friction Module**

The Montalvo Dual V Friction Module provides “No Tools” pad replacement on your Montalvo Standard and HP Series Dual Disc Brakes! Montalvo re-engineered its Standard friction module, used on both the Standard and HP Series dual disc brakes, allowing our patented “no-tools” V friction pad to be used for quick and easy pad changes. The versatile Dual V Friction Module design is an exact fit replacement to the Standard module making retrofits a snap. Standard pads are an available option for those wishing to maintain existing brakes that use Standard pads. So whether you are considering new brakes, maintaining or upgrading existing brakes, you now have the choice to decrease your down time with the Dual V Friction Module featuring “no-tools” pad change.

Features and Benefits

- ▶ Module upgrades Standard and HP Series dual disc brakes with patented V Pad
- ▶ No Tools friction pad maintenance - Change V Pads in seconds!
- ▶ Retrofit existing Standard and HP brakes to the V Pad advantage
- ▶ Standard Pads may be used if V Pads are not required
- ▶ Replaces dual cylinder friction module



Select a Brake

Standard Series

Accepts the new Dual Module with either V or Standard pads

HP Series

Accepts the new Dual Module with either V or Standard pads



Select a Friction Module

Dual Module with V Pads

No tools needed to change pads thus reducing downtime

Dual Module with Standard Pads

Uses the same Standard pads you've used in the past

Friction Pad Performance

Both the V pad and Standard pad are available in three friction coefficients. The pads are engineered to have the identical friction values, so no matter which pad style you select, brake performance will be the same.

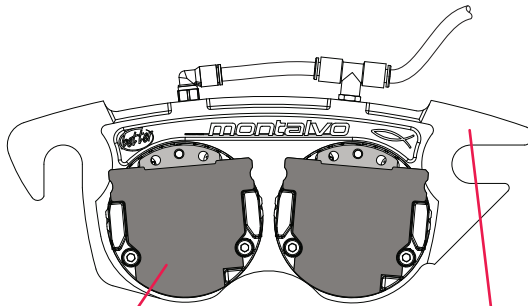
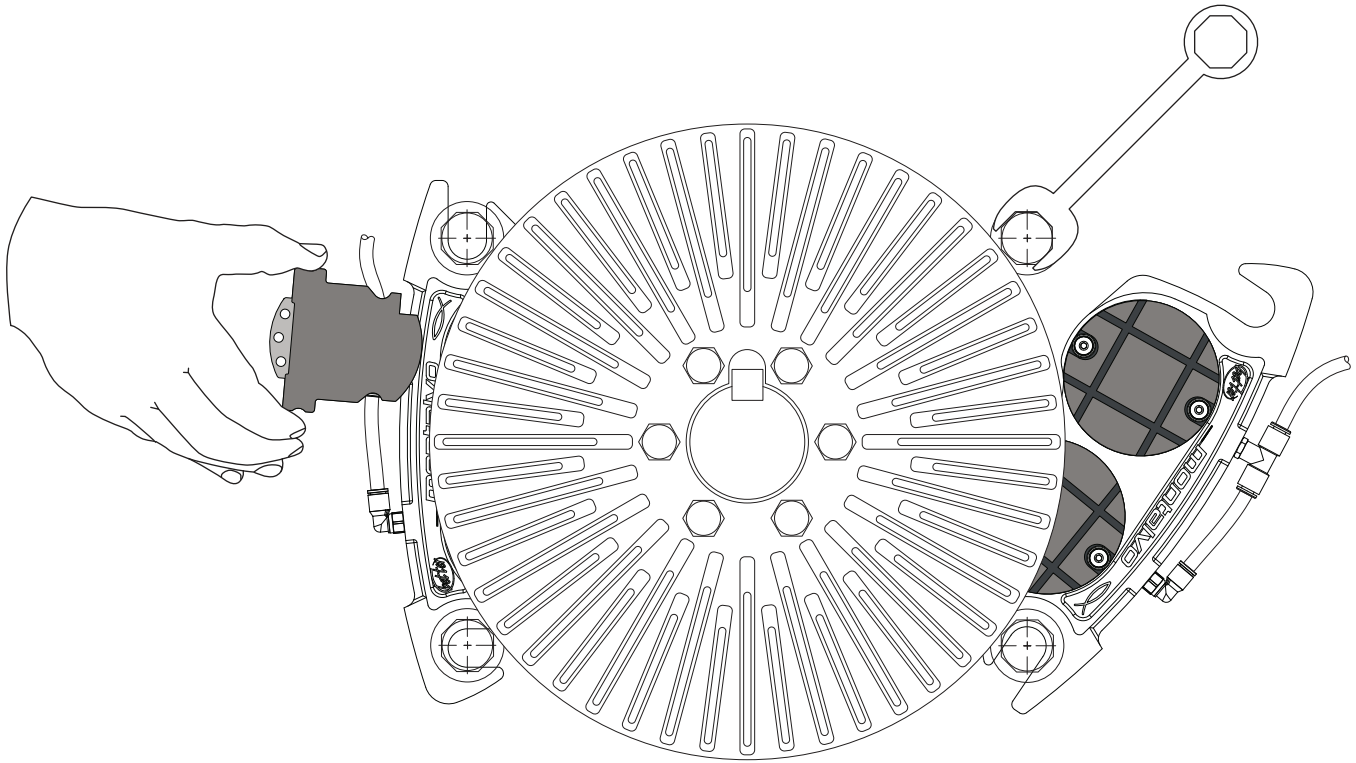

V Pads

Convenient on all Standard and HP brakes. A no tools pad change can shorten down time by over an hour per brake.

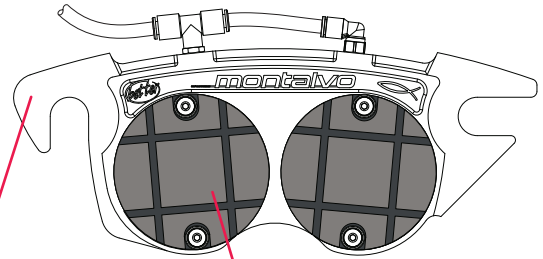

Standard Pads

Available as a module option allowing cutomers to use the same pads used in the past.

Dual Friction Module

Product upgrade for all new orders of Standard and HP series dual disc brakes.
Exact-fit replacement for existing Standard and HP brake friction modules.

Parts Description for Dual V module with V pads and pistons

- 1 V Friction pad (many types available)
- 2 SHCS M5x12 DIN912
- 3 V Torque Collar Kit
- 4 Standard Piston Magnet
- 5 V Piston Kit (magnet, piston, gasket)
- 6 Standard Piston Gasket
- 7 Dual V Friction Module Casting
- 8 Elbow Fitting (1/4")
- 9 Teflon Tubing (1/4")
- 10 Branch Tee Fitting (1/4")

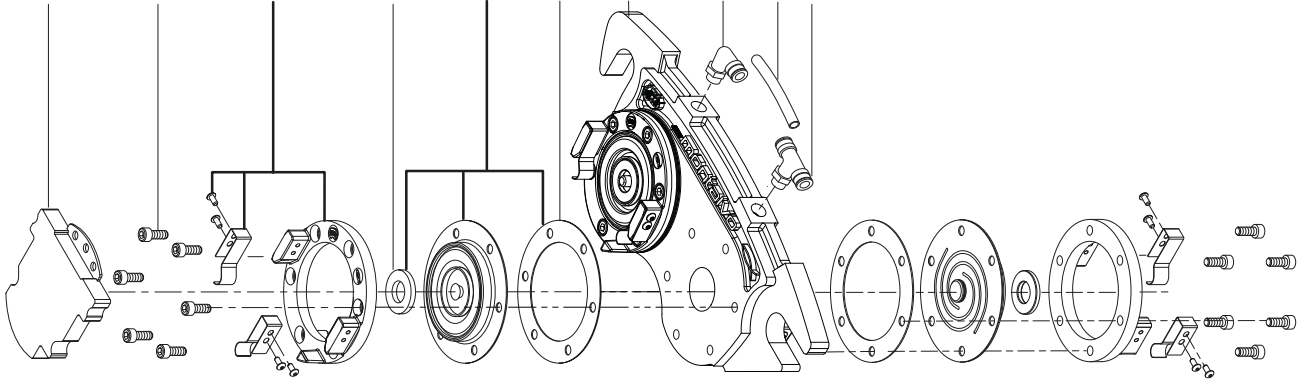
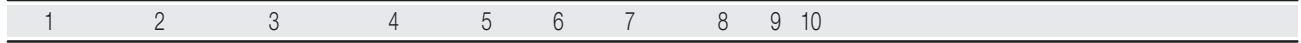
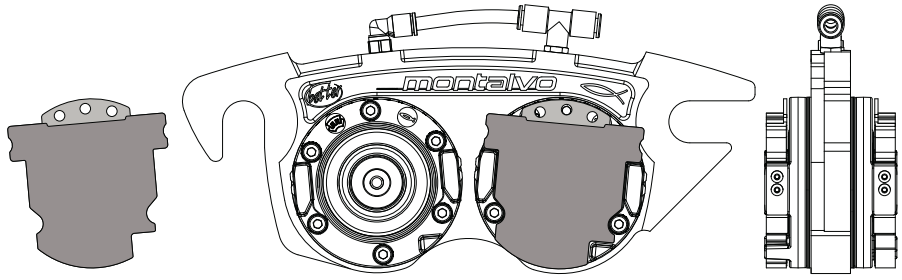

Parts Description for Dual S module with Standard pads and pistons

- 1 Friction pad (many types available)
- 2 Torque Post Screw SEM BHSS M5x0.8x25
- 3 Torque Post Kit (post and screw)
- 4 Torque Collar Screw SEM BHSS M5x0.8x18
- 5 Torque Collar Kit (posts, screws & collar)
- 6 Torque Collar
- 7 Standard Piston Magnet
- 8 Standard Piston Kit (magnet, piston, gasket)
- 9 Piston Gasket
- 10 Dual S Friction Module Casting
- 11 Elbow Fitting (1/4")
- 12 Teflon Tubing (1/4")
- 13 Branch Tee Fitting (1/4")

