

Defender**TA** Torque Activated Core Chucks**Montalvo Defender TA Core Chucks**

Self-expanding and self-blocking Torque Activated Core Chucks, designed with wider lugs to ensure minimal to no core damage, engage the core as a result of the reel's rolling action making it ideal for light or heavy continuous duty shaftless unwind or rewind applications (i.e. sheeting, paper, laminating, etc).

Features, Benefits and Options

- ▶ *No operator interaction, tools, or air required for expansion, retraction, and disengagement*
- ▶ *Industry leading jaw expansion*
- ▶ *Easy removal and insertion reducing risk of jammed cores*
- ▶ *Bi-directional operation*
- ▶ *Nickel Plated for corrosion resistance and long service life*
- ▶ *Smooth lugs/jaws available*

Single Core

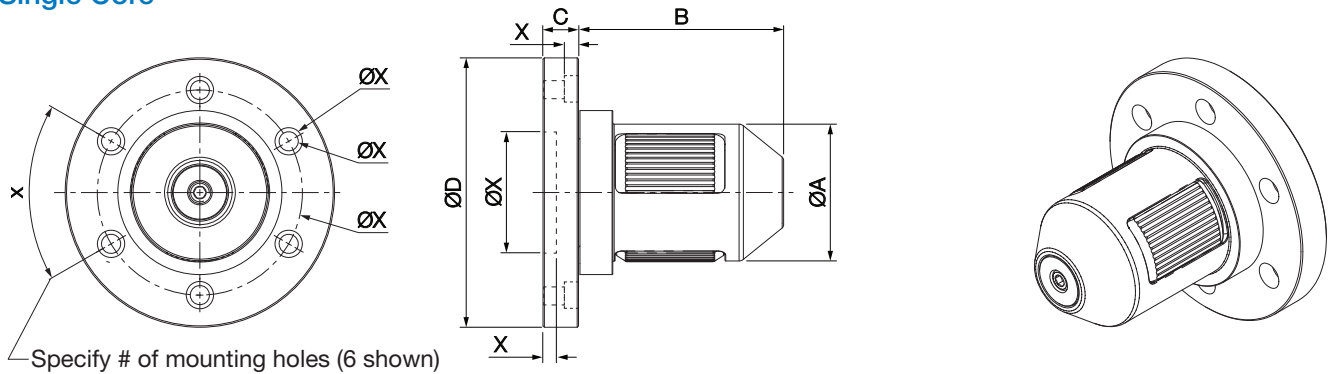

Model #	Core in (mm)	A in (mm)	B in (mm)	C in (mm)	D in (mm)	Expansion in (mm)	Max. Load* lb (N)	Max. Torque* in-lb (Nm)	X in (mm)
TA-S-3	3 (76)	2.94 (74.6)	5.91 (150)	0.98 (25)	7.01 (178)	2.95-3.31 (75-84)	4,046 (18,000)	10,178 (1,150)	Customer Specified
TA-S-4	4 (100)	3.86 (98)			7.72 (196)	3.88-4.21 (98.5-107)	8,317 (37,000)	22,126 (2,500)	
TA-S-6	6 (150)	5.83 (148)			8.50 (216)	5.85-6.22 (148.5-158)	24,728 (110,000)	44,253 (5,000)	

* Values are for a single chuck. Double the values when using chucks in pairs.

Single Core with E-Flange™ Option

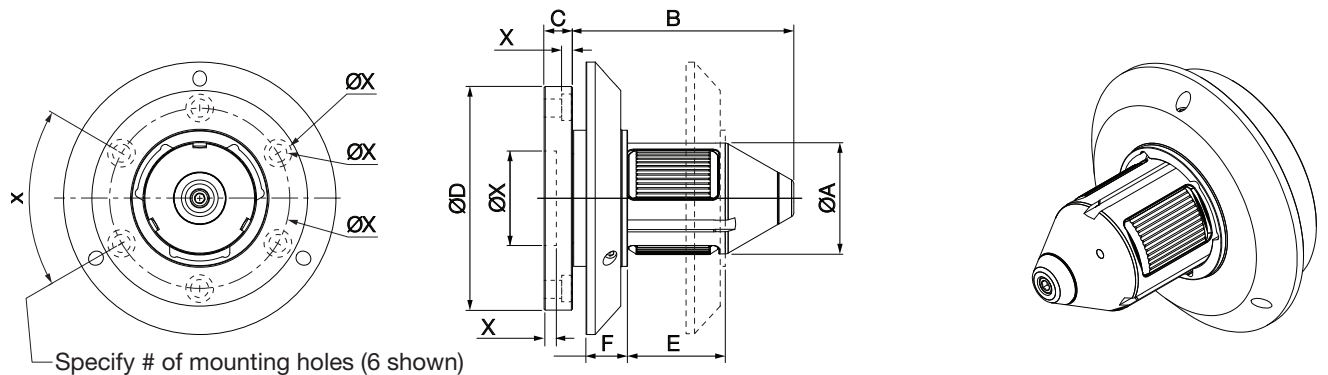

Model #	Core in (mm)	A in (mm)	B in (mm)	C in (mm)	D in (mm)	E in (mm)	F in (mm)	Max. Load* lb (N)	Max. Torque* in-lb (Nm)	X in (mm)
TA-S-3-E	3 (76)	2.94 (74.6)	9.17 (233)	0.98 (25)	7.01 (178)	3.94 (100)	0.79 (20)	4,046 (18,000)	10,178 (1,150)	Customer Specified
TA-S-4-E	4 (100)	3.86 (98)	9.57 (243)		7.68 (195)		1.57 (40)	8,317 (37,000)	22,126 (2,500)	

E = E-Flange (Ejector Flange option)

* Values are for a single chuck. Double the values when using chucks in pairs.

Single Core with K-Spring™ Option

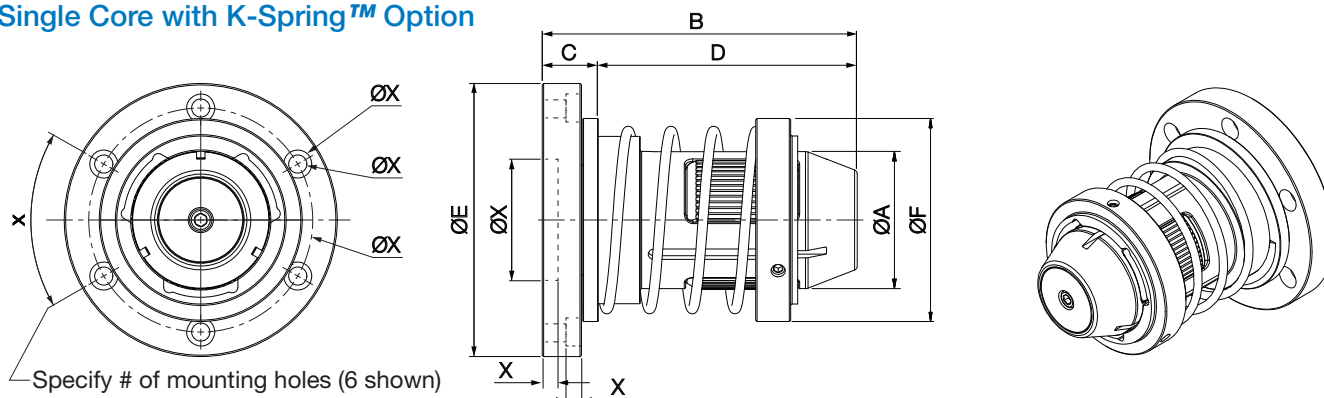

Model #	Core in (mm)	A in (mm)	B in (mm)	C in (mm)	D in (mm)	E in (mm)	F in (mm)	Expansion in (mm)	Max. Load* lb (N)	Max Torque* in-lb (Nm)	X in (mm)
TA-S-4-K	4 (100)	3.86 (98)	8.86 (225)	1.57 (40)	7.28 (185)	7.68 (195)	5.71 (145)	3.88-4.21 (98.5-107)	8,317 (37,000)	22,126 (2,500)	Customer Specified
TA-S-6-K	6 (150)	5.83 (148)	279.5 (11)	5.77 (146.5)	5.24 (133)	8.50 (216)	10.24 (260)	5.85-6.22 (148.5-158)	24,728 (110,000)	44,253 (5,000)	

K = Kick Spring

* Values are for a single chuck. Double the values when using chucks in pairs.

Dual Core

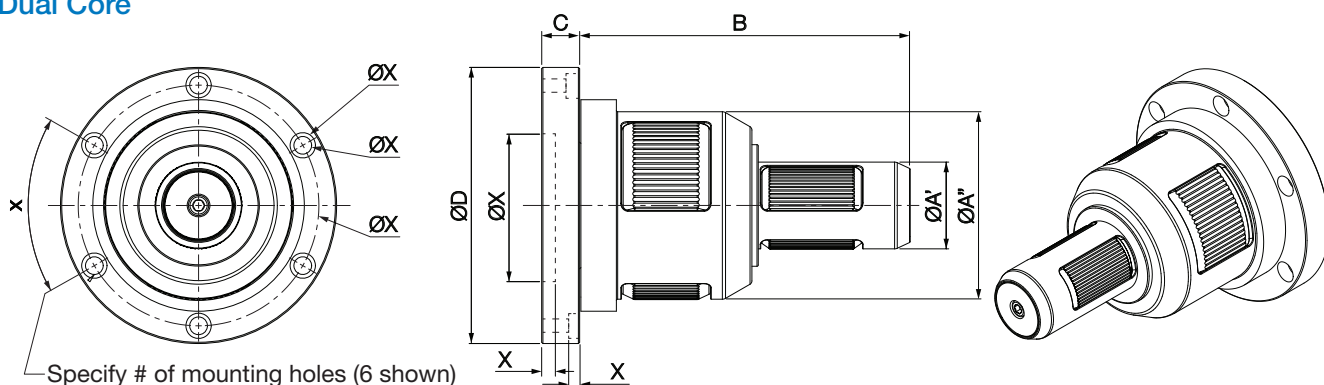

Model #	Cores	A' in (mm)	A'' in (mm)	B in (mm)	C in (mm)	D in (mm)	Expansion in (mm)	Max. Load* lb (N)	Max. Torque* in-lb (Nm)	X in (mm)
TA-D-3/4	3" & 4"	2.94 (74.6)	3.94 (100)	9.84 (250)	0.98 (25)	7.68 (195)	3.31/4.29 (84/109)	4,046/8,317 (18,000/37,000)	10,178/22,126 (1,150/2,500)	Customer Specified
TA-D-3/6	3" & 6"	2.94 (74.6)	5.91 (150)			8.50 (216)	3.31/6.26 (84/159)	4,046/24,728 (18,000/110,000)	10,178/22,126 (1,150/2,500)	
TA-D-4/6	4" & 6"	3.86 (98)	5.91 (150)			8.50 (216)	4.21/6.26 (107/159)	8,317/24,728 (37,000/110,000)	22,126/44,253 (2,500/5,000)	

* Values are for a single chuck. Double the values when using chucks in pairs.

Modular Core

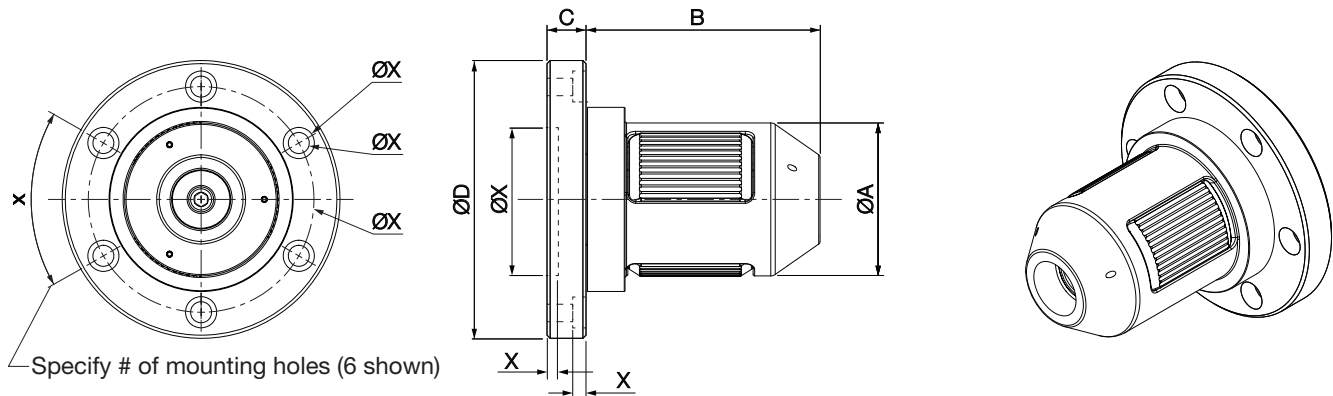

Model #	Core in (mm)	HUB in	A in (mm)	B in (mm)	C in (mm)	D in (mm)	Expansion in (mm)	Max. Load* lb (N)	Max. Torque* in-lb (Nm)	Cage Material	X in (mm)
TA-M-3-3	3 (76)	3	2.91 (74)	5.91 (150)	0.98 (25)	7.01 (178)	2.91-3.21 (74-81.5)	4,046 (18,000)	10,178 (1,150)	Steel	Customer Specified
TA-M-4-3	4 (100)		3.86 (98)				3.86-4.19 (98-106.5)			Steel	
TA-M-6-3	6 (150)		5.83 (148)				5.83-6.16 (148-156.5)			Steel	
TA-M-12-3	12 (300)		11.89 (302)				11.89-12.20 (302-310)			Aluminum	
TA-M-4-4	4 (100)	4	3.86 (98)	5.91 (150)	1.02 (26)	7.72 (196)	3.86-4.21 (98-107)	8,317 (37,000)	22,126 (2,500)	Steel	
TA-M-6-4	6 (150)		5.83 (148)				5.83-6.14 (148-156)			Steel	
TA-M-8-4	8 (200)		7.8 (198)				7.8-8.11 (198-206)			Aluminum	
TA-M-10-4	10 (245)		9.76 (248)				9.76-10.08 (248-256)			Aluminum	
TA-M-12-4	12 (300)	11.89 (302)	11.89-12.2 (302-310)	Aluminum							
TA-M-6-6	6 (150)	6	5.83 (148)	5.91 (150)	1.18 (30)	8.5 (216)	5.83-6.16 (148-156.5)	24,728 (110,000)	44,253 (5,000)	Steel	
TA-M-8-6	8 (200)		7.8 (198)				7.8-8.13 (198-206.5)			Aluminum	
TA-M-10-6	10 (245)		9.76 (248)				9.76-10.08 (248-256)			Aluminum	
TA-M-12-6	12 (300)		11.89 (302)				11.89-12.22 (302-310.5)			Aluminum	

* Values are for a single chuck. Double the values when using chucks in pairs.

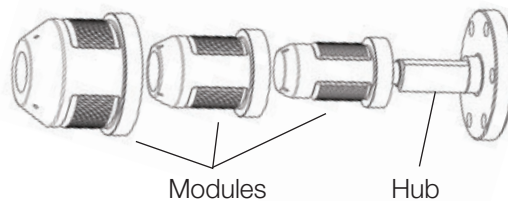

	207-856-2501 / 800-226-8710
	+86-21-52188010
	+45 75 57 27 11
	+49 (0)511 760 691 41



The Montalvo Corporation

EST. 1947



50 Hutcherson Drive, Gorham, Maine 04038 USA
 Fax: 1-800-644-5097 / 207-856-2509

1-800-226-8710 / info@montalvo.com / www.montalvo.com
 Technical details subject to change without notice. DTA-US-02 © Montalvo