

# VLC-Series

Individual End Tension Load Cells



Multi-Tow Tension Monitoring and Control

IP54

## Montalvo VLC Series Individual Tow Tension Load Cells

Introducing the Vanguard Load Cell, designed and built for the unique and often low-tension requirements of carbon, glass, textile, wire and more. The Vanguard Load Cell - VLC (a component of the Montalvo Vanguard System) is a specially designed load cell for providing precise, repeatable tension measurement of individual tows. A narrow, stackable profile, and a wide range of load rating options ensures the VLC Series meets the requirements of practically any process running tows or single strand materials.

Achieve precise tension measurement from start to finish, for higher quality end product and less scrap.

### Features and Benefits

- ▶ Beam sensitivity ranges - from 20g to 10kg
- ▶ Built-In Amplifier Available For Easy Connection To Existing I/O
- ▶ Precise, Repeatable Tension Measurement Of Individual Tows
- ▶ High Overload Protection
- ▶ Compact, Stackable Design To Meet Process Space Requirements
- ▶ Produces Superior Tension Signal For Maximum Accuracy
- ▶ Used For Providing Continuous Tension Indication Or Connect To A Control Scheme To Produce An Automated, Continuous Closed Loop Tension Control System



Dimensions

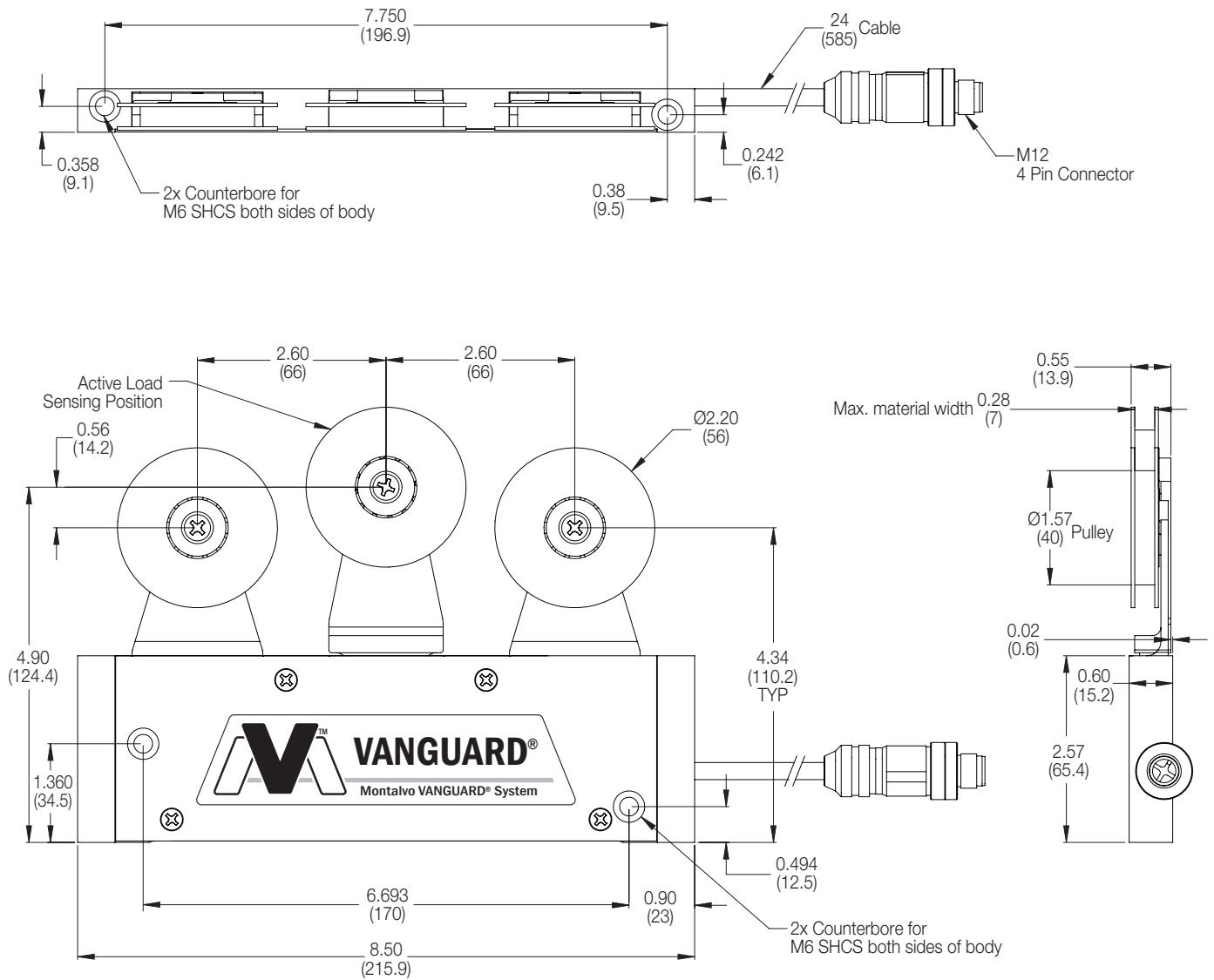
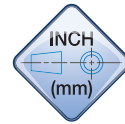

## How It Works

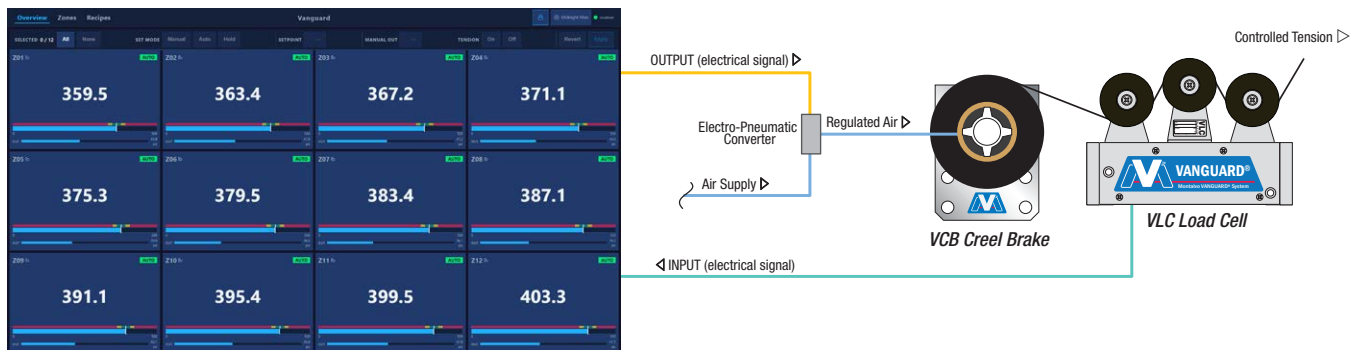

### Specifications

Power (with on board amplifier - standard)		24 VDC
Power (without on board amplifier - option)		5 VDC
Output-Nominal		25-50 mV/V
Gauge Resistance		80-130 Ω
Gauge Type		Half Bridge Semiconductor Strain Gauge
Non-Repeatability		±1.5 % full span
Non-Linearity and Hysteresis (combined)		±1.5 % full span
<b>Available Beam Load Rating</b>	VLC-02	0.44 lb (200 g)
	VLC-08	1.77 lb (800 g)
	VLC-12	2.65 lb (1.2 kg)
	VLC-20	4.4 lb (2 kg)
	VLC-50	11 lb (5 kg)
	VLC-100	22 lb (10 kg)
Overload Stops		110% of Load Rating
Overload Rating		150% of Load Rating
Axial Overload Rating		20% of Load Rating
Classification		IP54
Temperature - Operating Range		-4 to 150°F (-20 to 70°C)
Temperature Coefficient (% per degree)		0.02 (0.01) typ.
Body Finish		Aluminum
Roller Finish*		Anodized Aluminum



# The Montalvo VANGUARD® System (MVS)

The patented VANGUARD® System is Montalvo's flagship closed loop tow and tape tension control technology system, leading the way in precise, uniform, consistent, automated tension control.

## Tension Measurement (input)

Continuous, precise tension measurement directly from your tow. The VANGUARD Load Cells (VLC) feature Montalvo's industry-leading load cell technology for sensitivity, reliability, and repeatability.

- Beam sensitivity ranges - from 20g to 10kg
- Pre-Calibrated (Just Install & Go)
- Built-In Amplifier for Easy Connection to Existing I/O
- High Overload Protection
- Precise Tension Measurement

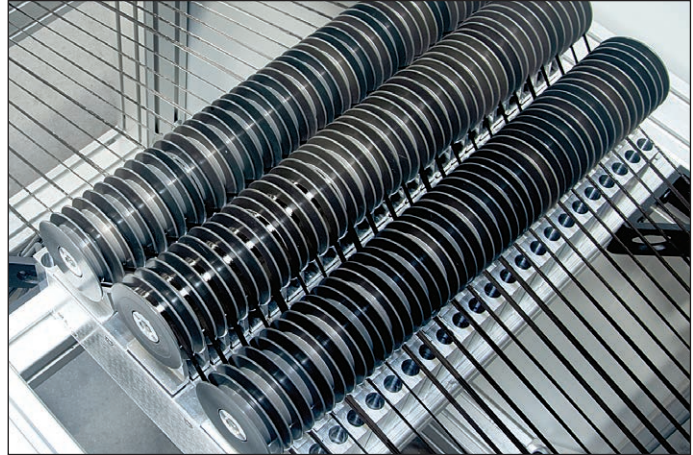

## Tension Control (process)

A single interface for automated control, and indication of every tow in your process. Montalvo's VANGUARD Tension Controller (VTC) is easy to set up and operate, automatically and precisely maintaining set tension from start to finish.

- Low/High Tension and Tow Break Alarms
- Single Interface for Managing Every Tow in Your Process
- Adjustable and Expandable Tow Counts

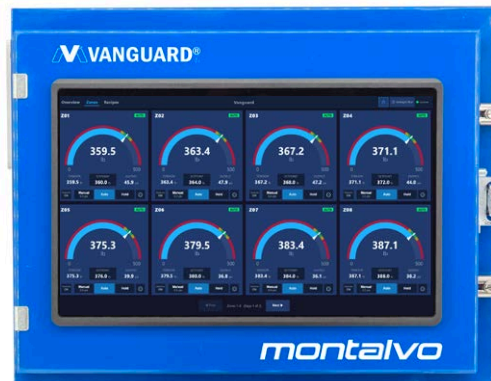

## Torque Control (output)

Smooth, consistent, precise torque control for maximum process capability. Montalvo's VANGUARD Torque Control offers three different torque control options depending on the requirements of your application.

- Wide Torque Ranges and Tension Profiles Capable of a Wide Variety of Materials and Tensions
- Easy, Hassle-Free Installation
- Long-Lasting, High-Quality Performance
- Retrofit Capable – Upgrade Your Existing Creels

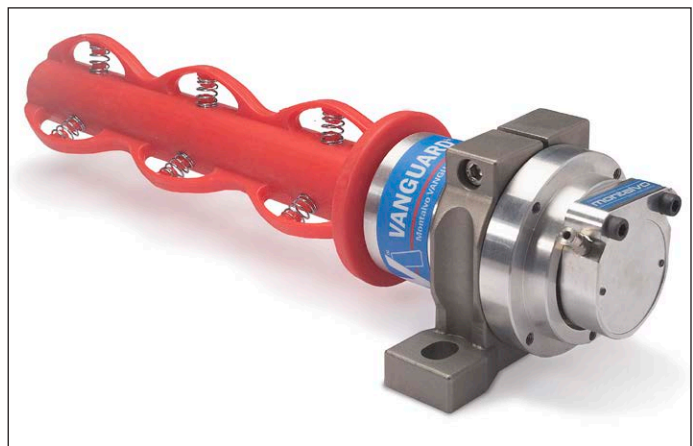

	207-856-2501 / 800-226-8710	
	+86-21-52188010	
	+45 75 57 27 11	
	+49 (0)511 760 691 41	



The Montalvo Corporation

EST. 1947

# montalvo

Better Web Control®

50 Hutcherson Drive, Gorham, Maine 04038 USA  
Fax: 1-800-644-5097 / 207-856-2509

1-800-226-8710 / info@montalvo.com / www.montalvo.com

Technical details subject to change without notice. MMVS-VLC-US-080524© Montalvo